



Modular ice maker up to 165 kg - Granular system

| | |
|---------------|----------------------|
| Hotel | ████████████████████ |
| Restaurant | ████████████████████ |
| Fast food | ████████████████████ |
| Bar | ████████████████████ |
| Disco | ████████████████████ |
| Fish market | ████████████████████ |
| Supermarket | ████████████████████ |
| Medical & SPA | ████████████████████ |
| Industry | ████████████████████ |

► Position n°



► Features & Plus

- Granular ice - 80-82% dry
- 1l (water) - 1kg (ice) - only Air cooled
- AISI 304 SS Scotch Brite finish
- Tropical class +43°C
- Specific volume 1 m³ = 550 kg of ice
- Removable and cleanable air filter
- AISI 304 SS evaporator
- Air or water cooling system
- Easy cleanable internal rounded surfaces
- Dust-proof water basin
- RoHS Free
- Electromechanical operation
- ON-OFF rocker switch
- Automatic water charge
- Standard and special voltages
- Frame in INOX

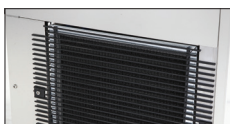

Removable and cleanable air filter



AISI 304 SS evaporator



Dust-proof water basin



Frame in INOX

► Usable Bins

- Bin 240PE
- Bin 110
- Bin 200
- Roller Bin 100

► Prod. 24h

| °C | Air temp. | | Water temp. | | Kg | Lbs |
|----|-----------|-------|-------------|-------|-----|-----|
| | 10° C | 50° F | 10° C | 50° F | | |
| | 21° C | 70° F | 15° C | 60° F | | |
| | | | | | 165 | 364 |
| | | | | | 160 | 353 |

2 Years Warranty
subject to limitations

► Certifications available for this model



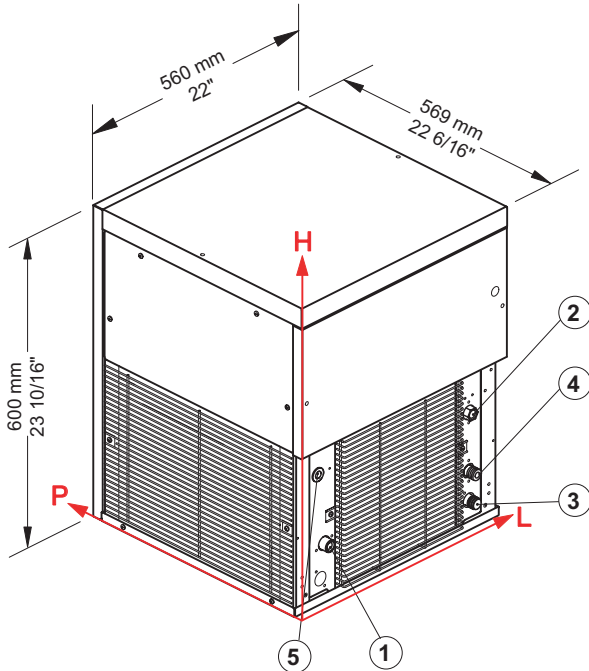

Ice Flakes

G 160**Modular ice maker up to 165 kg - Granular system****► Working conditions**

- Location: **Indoor**

| | Min | Max |
|----------------------|-----------------|-----------------|
| Ambient temperature | +10° C / +50° F | +43° C / 110° F |
| Water temperature | +3° C / +37° F | +32° C / +90° F |
| Voltage | -10% | +10% |
| Water inlet pressure | 1bar (14 psi) | 6bar (84 psi) |

► Performances

| | Air temperature | Water temperature | | | | | |
|--|-----------------|-------------------|---------|--------|---------|--------|---------|
| | | 10° C | 50° F | 15° C | 60° F | 21° C | 70° F |
| | 10° C | 165 kg | | | | | |
| | 50° F | | 364 lbs | | | | |
| | 21° C | | | 160 kg | | | |
| | 70° F | | | | 353 lbs | | |
| | 32° C | | | | | 135 kg | |
| | 90° F | | | | | | 298 lbs |

► Connections

All measures are referred to the down-left corner (L-H-Ø)

- ① Water in.: 85,5 mm / 3 6/16" - 130 mm / 5 2/16" - 3/4"
- ② Cond. water in.: 479,5 mm / 18 14/16" - 260 mm / 10 4/16" - 3/4"
- ③ Water out.: 479,5 mm / 18 14/16" - 65 mm / 2 9/16" - 24 mm / 15/16"
- ④ Cond. water out.: 479,5 mm / 18 14/16" - 130 mm / 5 2/16" - 24 mm / 15/16"
- ⑤ Electrical connections: 67,5 mm / 2 11/16" - 290 mm / 11 7/16"
- ② ④ Only for water cooling systems

► Technical information

| | | | |
|------------------------|--|----------------------------|--|
| Production in 24h | 160 kg / 353 lbs | Sizes (L-P-H mm) | 560 - 569 - 600 |
| Cooling system | A - W | (L-P-H in) | 22 - 22 6/16 - 23 10/16 |
| Refrigerant | R404A | Sizes with pack (L-P-H mm) | 645 - 645 - 810 |
| Standard voltage | 220-240 V ~ 50 Hz | (L-P-H in) | 25 6/16 - 25 6/16 - 31 14/16 |
| Electrical consumption | 650 W | Net weight | 63 kg / 139 lbs |
| Fuse | 10 A | Gross weight | 74 kg / 163 lbs |
| Water consumption | A: 1 l/kg - 12,0 gal/100 lbs W: 5,5 l/kg - 65,9 gal/100 lbs | Finish | AISI 304 stainless steel, scotch brite |

All the technical information need to be considered at the following conditions:
 Ambient temperature +21° C
 Water temperature +15° C
 Electrical consumption at +43° C (standard voltage)

Models and specifications are subject to change without notice

Rev. 01 - Issued January 2016

**BREMA ICE MAKERS SPA**Via dell'Industria 10,
20020 Villa Cortese (MI), Italytel. +39 0331 434811
fax +39 0331 433833www.bremaice.it
info@bremaice.itBim + Data
download

Installation



We are Brema

