



PROFESSIONAL  
HOSTELRY  
AND BAKERY

2018



# GENERAL CATALOG 2018





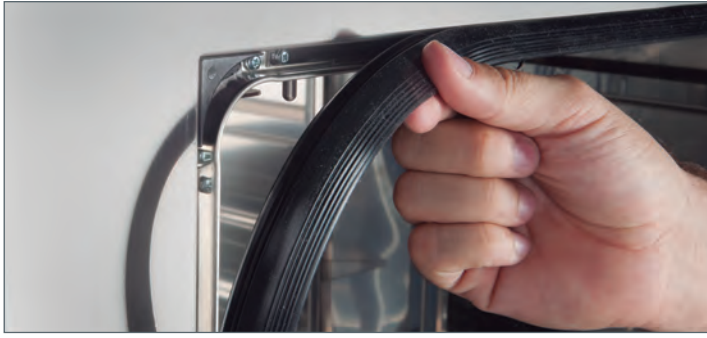

## **REMOVABLE DOOR GASKET**

*System that significantly increases seal life, provides the escape of heat from the oven, and hermetically close the door.*



## **HINGE REINFORCEMENT**

*FM exclusive component that transmits the pressure to the hinge structure Inside of the oven, making reliable and durable this component.*



## **HIGH DENSITY INSULATION**

*It provides more energy efficiency and increased thermal stability, reducing cooking/ baking cycle periods and extending thermostat and components life time.*



## **MOTOR AND TURBINE**

*With the regularization of engines and turbines for all types of food, they provide more optimal and homogeneous results.*





## **SAFETY ELECTRICAL CONNECTIONS**

*Coupling power wiring by screws, ensuring a perfect connection and prevents low-quality joints.*



## **LOW EMISSION CRISTALS**

*This feature allows the incorporated glass decrease energy losses of the cooking cycle and safe manipulation of the oven door by lowering the temperature of the outer glass.*

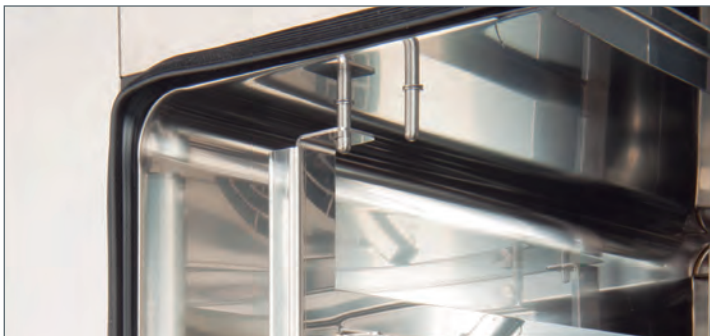

## **ROUNDED INSIDE CORNERS**

*Allow uniform air circulation and facilitate cleaning of the chamber, complying the HACCP norms.*



## **INTUITIVE TOUCH SCREEN**

*Facilitates daily use and reduces learning time, focused to the most frequent cooking. Constant monitoring of all the processes.*



## SERIES **ST COMPACT**

pages 12 - 17 - *HOSTELRY*



## SERIES **ST**

pages 18 - 32 - *HOSTELRY AND BAKERY*



## SERIES **F**

pages 33 - 39 - *HOSTELRY*



## SERIES **RXB**

pages 40 - 49 - *HOSTELRY AND BAKERY*



## SERIES **RX**

pages 50 - 59 - *BAKERY*



## SERIES **M/ME**

pages 60 - 67 - *BAKERY*



# PROVER

pages 68 - 69



# TOASTER

pages 70 - 73



# PIZZA OVEN

pages 74 - 77



# REGENERATOR

pages 78 - 81



# GRILL

pages 82 - 83



# ACCESORIES

pages 84 - 96











# SMART SYSTEM

## TOUCH SCREEN ST SERIES

SMART SYSTEM



-  Temperature range 30°-270°
-  Steam / combination / connection cooking
-  Core probe
-  Delta T
-  Adjustable motor speed
-  Recipe book
-  Favorites
-  Automatic program ignition
-  Multicook / Multilevel



Program for automatic ignition switch on/off

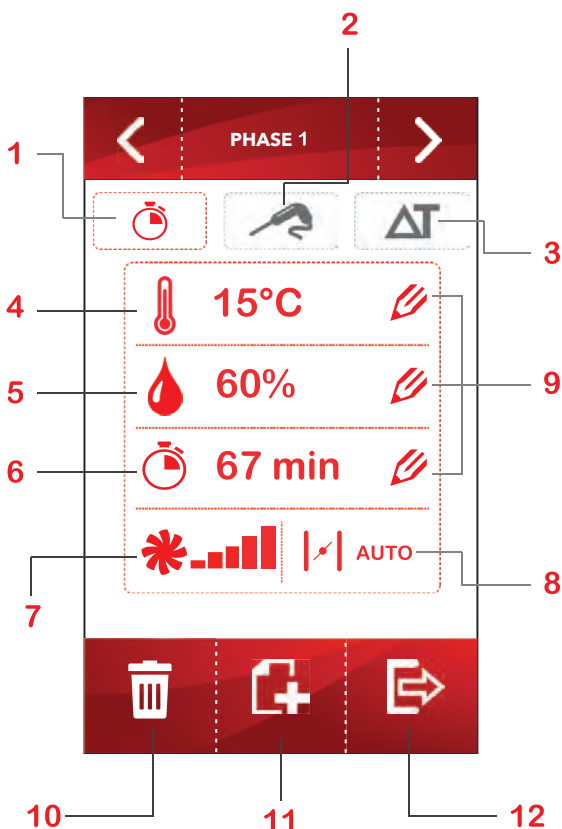

- 1 Cooking mode with time
- 2 Cooking mode with core probe
- 3 Cooking mode with Delta T
- 4 Temperature programming
- 5 Humidity programming
- 6 Time programming
- 7 Motor speed
- 8 Steam extration
- 9 Editing values
- 10 Delate prograded phase
- 11 Add cooking phase
- 12 Start cooking
- 13 Recipe FM Industrial
- 14 Chef recipe

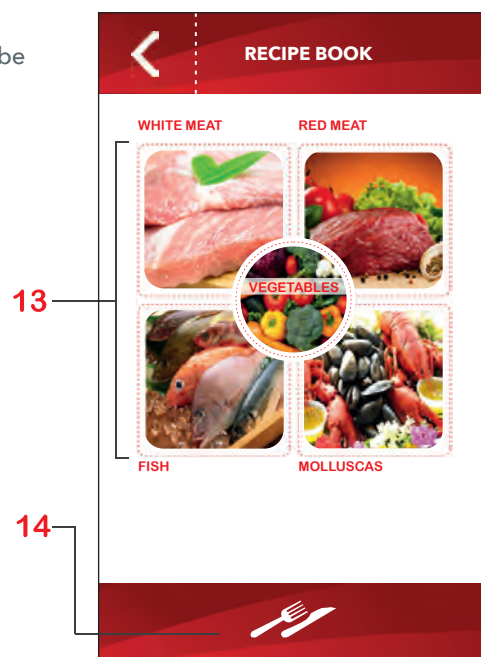

# MULTICOOK

This system allow you to cook different food with different cooking time, letting you know as the trays are ready.

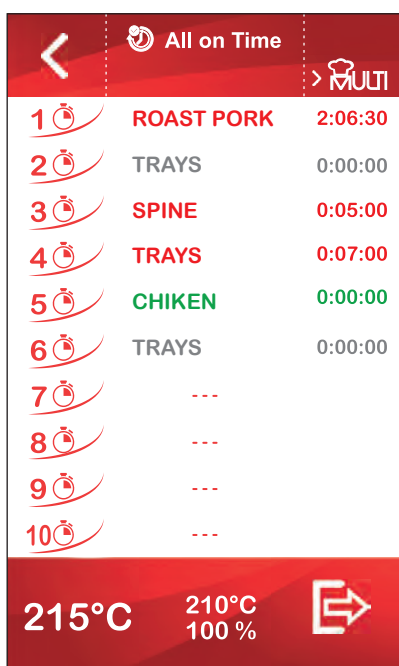
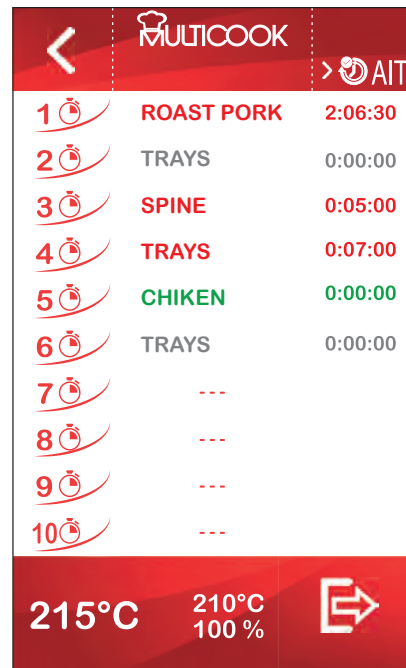
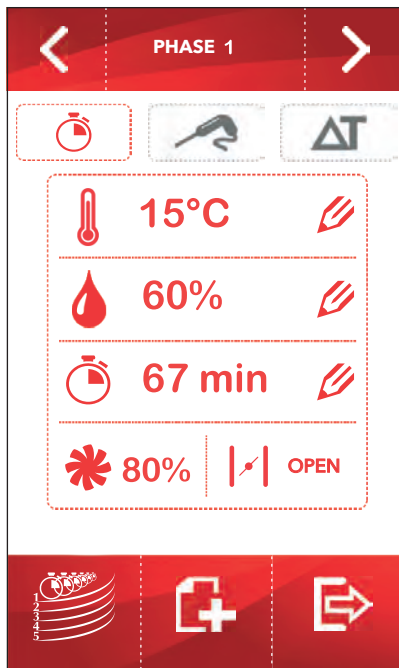

## ALL ON TIME

This function allow you to cook different food whit the end of the product at the same time, for this the oven tells as when to introduce each tray. The result is the simultaneous completion of all foods.



## MANUAL COOKING

Set your cooking program for any food quickly and intuitively without the need to complicated processes for the elaboration of their recipes.

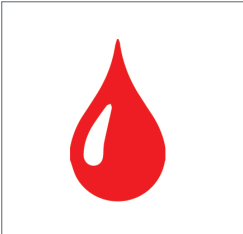

## CLIMATE CONTROL

With the "Climate Control" system the oven will adapt the perfect climate in the cooking chamber to get desired finish in the food without the need for select cooking modes previously. Delete complex recipe processing processes, choose time, temperature, humidity and this system will do the rest.



## FAN Adjustable-speed control

Thanks to the possibility of regulating the speed of the fans (up to 10 speeds) you can cook any type of food, however delicate it may be, thanks to the bi-directionality of the fan you will obtain a perfect cooking uniformity.

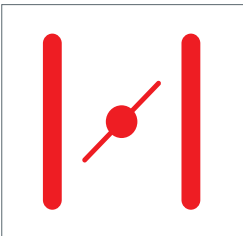

## STEAM CONTROL

The Steam control system allows a controlled vapor outlet inside the chamber, managing to extract or maintain the humidity inside the chamber. This way we will be able to obtain uniform golds, perfect roasts of meat, gratin, etc.



## DELTA T

Thanks to the constant temperature difference between the interior of the product and the cooking chamber, you will obtain homogeneous cooking in large pieces.

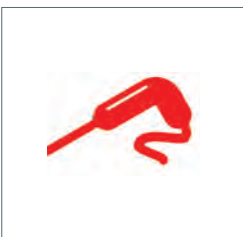

## PRODUCT HEART PROBE

Always get the desired cooking point thanks to the precise reading and control of the temperature inside the food regardless of the size of the food.







### **Core Probe** (*vacuum probe*)

With the vacuum core probe of only 1.5 mm in diameter, it will allow you to control the cooking temperature inside the product without breaking the vacuum process.

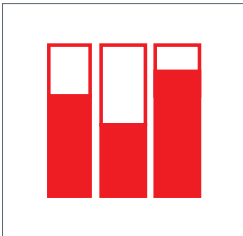

### **COOKING PHASES**

With the phase programming you can set cooking at different temperatures and humidifies in the same cooking cycle. In this way you can cook the food and brown or gratin at the end of the process.



### **REGENERATION / MAINTENANCE**

With this function we will be able to maintain the quality of the food by raising the refrigerated, frozen and packaged foods to a temperature of consumption in a short period of time.

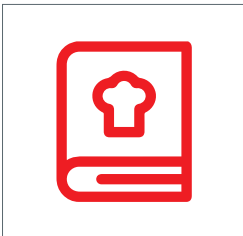

### **RECIPE BOOK**

All our ovens with Smart System V7 include a recipe with images and recipes already preset as standard. This recipe allows to be edited to suit each type of client.

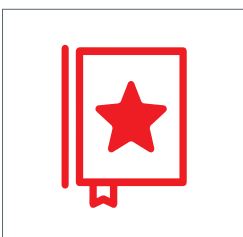

### **FAVORITES**

You will always have the last ten recipes used. To speed up the work you usually do.

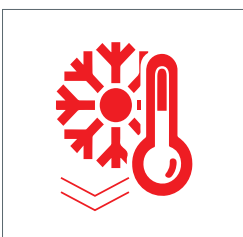

### **COOL DOWN / PREHEAT**

Quickly achieve the ideal cooking conditions inside the oven thanks to the Preheat (preheat) and Cool Down functions.



# ST COMPACT

*Minimo space, maximun results.*

Get the maximun performance with the compact range in a minimun space.  
You can steam, roast, fry browwn, fry, regenerate, and maintain.

## STC 611

REF. 710365



NEW

# ST COMPACT

*new transversal line.*

New compact ovens with transversal design and lower background.  
The best result for your recipes in the smallest space  
and with the best performance!

## STC 611 W

REF. 710417



HOSTELRY



## STC 423

REF. 710362



## STC 411

REF. 710363

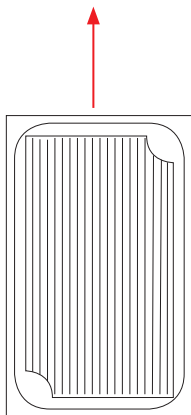





8 x GN 2/3 Prof. 20 | 4 x GN 2/3 Prof. 40 | 3 x GN 2/3 Prof. 65

8 x GN 1/1 Prof. 20 | 4 x GN 1/1 Prof. 40 | 3 x GN 1/1 Prof. 65







### EQUIPMENT

- Climate Control-adjustable humidity
- 6 Cooking phases
- Cycle end alarm
- Folding inner glass for cleaning
- Fan Control-adjustable speed
- Regeneration / Maintenance
- Door sensor
- Reversing gear
- Steam Control-adjustable chimney
- Recipe book
- Safety thermostat
- USB port
- Delta T
- Favorites
- LED chamber light
- HACCP
- External Core Probe connection
- Cool Down / Preheat
- Water connection  $\frac{3}{4}$
- Multi Level

### FEATURES

Power		3.700 W
Max temperature		270° C
Weight		45 Kg.
Voltage		230 V - L+N - 50/60 Hz
Connection		SINGLE PHASE
Cooking chamber dimension		(W)356 x (D)385 x (H)302 mm.
External dimension		(W)515 x (D)620 x (H)580 mm.
<b>RRP</b>		
Change opening door		
Automatic washing system		Included
Core Probe		Included

### FEATURES

Power		5.700 W
Max temperature		270° C
Weight		57 Kg.
Voltage		400 V - 3L+N - 50/60 Hz
Connection		THREE PHASE
Cooking chamber dimension		(W)356 x (D)560 x (H)302 mm.
External dimension		(W)515 x (D)795 x (H)580 mm.
<b>RRP STC 411</b>		
Change opening door		
Automatic washing system		Included
Core Probe		Included
<b>RRP STC 411 ECO 710364</b>		
Connection		SINGLE PHASE
Power		3700 W
Voltage		230 V - L+N - 50/60 Hz

# STC 411 W

REF. 710416

NEW

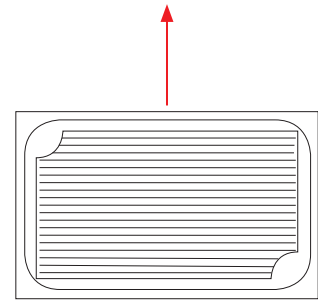
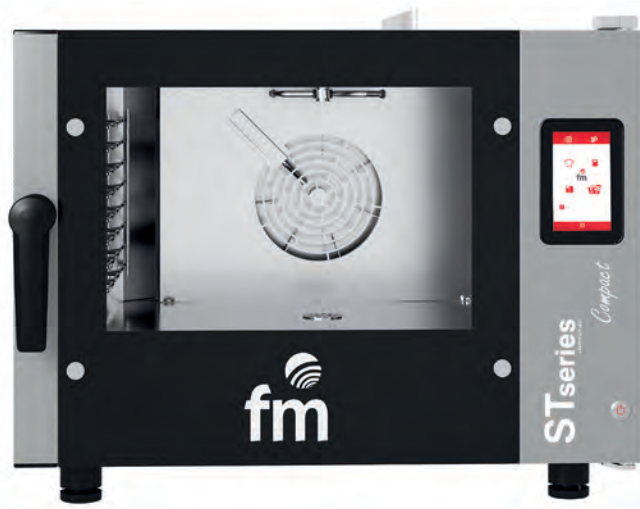







8 x GN 1/1 Prof. 20    4 x GN 1/1 Prof. 40    3 x GN 1/1 Prof. 65

## EQUIPMENT

- Climate Control-adjustable humidity
- Fan Control-adjustable speed
- Steam Control-adjustable chimney
- Delta T
- External Core Probe connection
- 6 Cooking phases
- Regeneration / Maintenance
- Recipe book
- Favorites
- Cool Down / Preheat
- Cycle end alarm
- Door sensor
- Safety thermostat
- LED chamber light
- Water connection  $\frac{3}{4}$
- Folding inner glass for cleaning
- Reversing gear
- USB port
- HACCP
- Multi Level

## FEATURES

Power		5.700 W
Max temperature		270° C
Weight		57 Kg.
Voltage		400 V - 3L+N - 50/60 Hz
Connection		SINGLE PHASE / THREE PHASE
Cooking chamber dimension		(W)561 x (D)384 x (H)303 mm.
External dimension		(W)720 x (D)620 x (H)580 mm.
<b>RRP STC 411 W</b>		
Change opening door		
Automatic washing system		Included
Core Probe		Included
<b>RRP STC 411 W ECO</b>		
Connection		SINGLE PHASE
Power		3700 W
Voltage		230 V - L+N - 50/60 Hz

# STC 611 W

REF. 710417

NEW

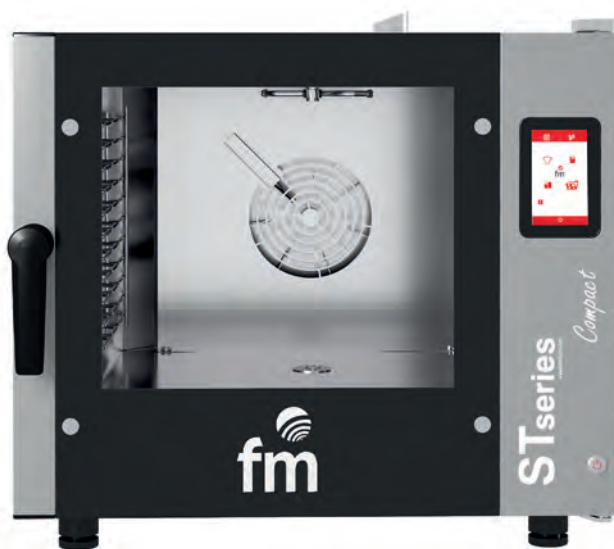
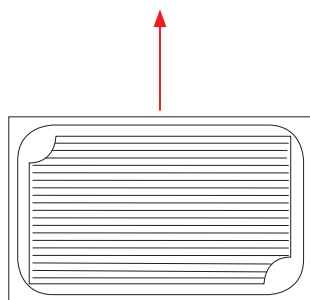

11 x GN 1/1 Prof. 20





6 x GN 1/1 Prof. 40

4 x GN 1/1 Prof. 65

## EQUIPMENT

- Climate Control-adjustable humidity
- Fan Control-adjustable speed
- Steam Control-adjustable chimney
- Delta T
- External Core Probe connection
- 6 Cooking phases
- Regeneration / Maintenance
- Recipe book
- Favorites
- Cool Down / Preheat
- Cycle end alarm
- Door sensor
- Safety thermostat
- LED chamber light
- Water connection ¾
- Folding inner glass for cleaning
- Reversing gear
- USB port
- HACCP
- Multi Level

## FEATURES

Power		7.200 W
Max temperature		270° C
Weight		65 Kg.
Voltage		400 V - 3L+N - 50/60 Hz
Connection		Three phase 3F + N + T
Cooking chamber dimension		(W)561 x (D)384 x (H)385 mm.
External dimension		(W)720 x (D)620 x (H)665 mm.
<b>RRP</b>		
Change opening door		
Automatic washing system		Included
Core Probe		Included

# STC 611

REF. 710365



# STC 1011

REF. 710366

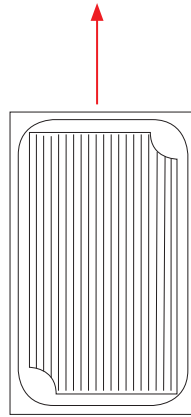





11 x GN 1/1 Prof. 20    6 x GN 1/1 Prof. 40    4 x GN 1/1 Prof. 65

19 x GN 1/1 Prof. 20    10 x GN 1/1 Prof. 40    6 x GN 1/1 Prof. 65





## EQUIPMENT

- Climate Control-adjustable humidity
- Fan Control-adjustable speed
- Steam Control-adjustable chimney
- Delta T
- External Core Probe connection
- 6 Cooking phases
- Regeneration / Maintenance
- Recipe book
- Favorites
- Cool Down / Preheat
- Cycle end alarm
- Door sensor
- Safety thermostat
- LED chamber light
- Water connection 3/4"
- Folding inner glass for cleaning
- Reversing gear
- USB port
- HACCP
- Multi Level

### FEATURES

Power		7.200 W
Max temperature		270° C
Weight		65 Kg.
Voltage		400 V - 3L+N - 50/60 Hz
Connection		Three phase 3F + N + T
Cooking chamber dimension		(W)356 x (D)560 x (H)385 mm.
External dimension		(W)515 x (D)795 x (H)665 mm.
<b>RRP</b>		
Change opening door		
Automatic washing system		Included
Core Probe		Included

### FEATURES

Power		11.400 W
Max temperature		270° C
Weight		90 Kg.
Voltage		400 V - 3L+N - 50/60 Hz
Connection		Three phase 3F + N + T
Cooking chamber dimension		(W)356 x (D)560 x (H)605 mm.
External dimension		(W)515 x (D)795 x (H)885 mm.
<b>RRP</b>		
Change opening door		
Automatic washing system		Included
Core Probe		Included





# SERIES ST

MULTILEVEL MIXED OVENS





# ST 604

REF. 710316

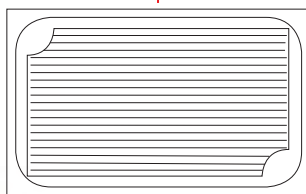

# ST 604 GAS

REF. 710318



4 x 600 x 400

4 x GN 1/1

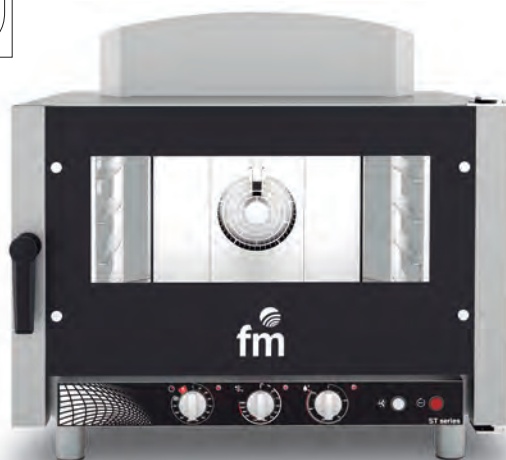





4 x 600 x 400

4 x GN 1/1





## EQUIPMENT

- Cycle end alarm
- Door safety switch
- Safety thermostat
- Halogen chamber light
- Water connection 3/4
- Folding inner glass for cleaning
- Reversing gear
- Double speed fan
- Timer 0-120 min. + continuous mode
- Adjustable humidity 0-100%

### FEATURES

Power		7.500 W
Max temperature		250° C
Weight		85 Kg.
Voltage		400 V - 50/60 Hz
Connection		Three phase 3F + N + T
Cooking chamber dimension		(W)700 x (D)500 x (H)390 mm.
External dimension		(W)880 x (D)935 x (H)710 mm.
Distance between trays		80 mm.
<b>RRP</b>		
Change opening door		

### FEATURES

Power		200 W
Gas power		9 kW_7740 Kcal/h
Max temperature		250° C
Weight		93 Kg.
Voltage		230 V - 50/60 Hz
Connection		SINGLE PHASE
Cooking chamber dimension		(W)700 x (D)500 x (H)390 mm.
External dimension		(W)880 x (D)935 x (H)900 mm.
Distance between trays		80 mm.
<b>RRP</b>		
Change opening door		
Natural gas		Under request
Chimney diameter		ø 100 mm.

# ST 604 V7

REF. 710317

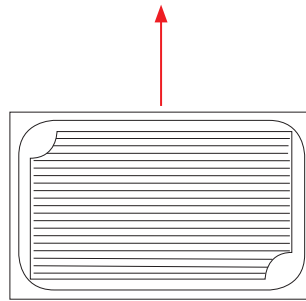

# ST 604 V7 GAS

REF. 710294



4 x 600 x 400

4 x GN 1/1







4 x 600 x 400

4 x GN 1/1





## EQUIPMENT

- Climate Control-adjustable humidity
- Fan Control-adjustable speed
- Steam Control-adjustable chimney
- Delta T
- External Core Probe connection
- Cooking phases
- Regeneration / Maintenance
- Recipe book
- Favorites
- Cool Down / Preheat
- Cycle end alarm
- Door sensor
- Safety thermostat
- LED chamber light
- Water connection 3/4
- Folding inner glass for cleaning
- Reversing gear
- USB port
- HACCP
- Multi Level

### FEATURES

Power		7.500 W
Max temperature		270° C
Weight		90 Kg.
Voltage		400 V - 50/60 Hz
Connection		Three phase 3F + N + T
Cooking chamber dimension		(W)700 x (D)500 x (H)390 mm.
External dimension		(W)880 x (D)935 x (H)710 mm.
Distance between trays		80 mm.
<b>RRP</b>		
Change opening door		
Automatic washing system		Included
Core Prober		Included

### FEATURES

Power		400 W
Gas power		9 kW_7740 Kcal/h
Max temperature		270° C
Weight		98 Kg.
Voltage		230 V - 50/60 Hz
Connection		SINGLE PHASE
Cooking chamber dimension		(W)700 x (D)500 x (H)390 mm.
External dimension		(W)880 x (D)935 x (H)900 mm.
Distance between trays		80 mm.
<b>RRP</b>		
Change opening door		
Automatic washing system		Included
Core Prober		Included
Natural gas		Under request
Chimney diameter		ø 100 mm.



# ST 606

REF. 710319

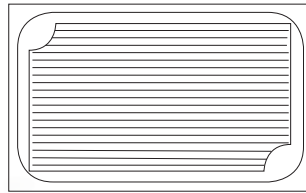

# ST 606 GAS

REF. 710320



6 x 600 x 400

6 x GN 1/1







6 x 600 x 400

6 x GN 1/1





## EQUIPMENT

- Cycle end alarm
- Door safety switch
- Safety thermostat
- Halogen chamber light
- Water connection 3/4"
- Folding inner glass for cleaning
- Reversing gear
- Double speed fan
- Timer 0-120 min. + continuous mode
- Adjustable humidity 0-100%

### FEATURES

Power		10.500 W
Max temperature		250° C
Weight		97 Kg.
Voltage		400 V - 50/60 Hz
Connection		Three phase 3F + N + T
Cooking chamber dimension		(W)700 x (D)500 x (H)550 mm.
External dimension		(W)880 x (D)935 x (H)870 mm.
Distance between trays		80 mm.
<b>RRP</b>		
Change opening door		

### FEATURES

Power		400 W
Gas power		14 kW_12040 Kcal/h
Max temperature		250° C
Weight		108 Kg.
Voltage		230 V - 50/60 Hz
Connection		SINGLE PHASE
Cooking chamber dimension		(W)700 x (D)500 x (H)550 mm.
External dimension		(W)880 x (D)935 x (H)1060 mm.
Distance between trays		80 mm.
<b>RRP</b>		
Change opening door		
Natural gas		Under request
Chimney diameter		ø 150 mm.

# ST 606 V7

REF. 710295

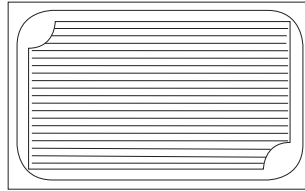

# ST 606 V7 GAS

REF. 710321



6 x 600 x 400

6 x GN 1/1



6 x 600 x 400

6 x GN 1/1





## EQUIPMENT

- Climate Control-adjustable humidity
- Fan Control-adjustable speed
- Steam Control-adjustable chimney
- Delta T
- External Core Probe connection
- 6 Cooking phases
- Regeneration / Maintenance
- Recipe book
- Favorites
- Cool Down / Preheat
- Cycle end alarm
- Door sensor
- Safety thermostat
- LED chamber light
- Water connection 3/4
- Folding inner glass for cleaning
- Reversing gear
- USB port
- HACCP
- Multi Level

### FEATURES

Power		10.500 W
Max temperature		270° C
Weight		102 Kg.
Voltage		400 V - 50/60 Hz
Connection		Three phase 3F + N + T
Cooking chamber dimension		(W)700 x (D)500 x (H)550 mm.
External dimension		(W)880 x (D)935 x (H)870 mm.
Distance between trays		80 mm.
<b>RRP</b>		
Change opening door		
Automatic washing system		Included
Core Prober		Included

### FEATURES

Power		400 W
Gas power		14 kW_12040 Kcal/h
Max temperature		270° C
Weight		113 Kg.
Voltage		230 V - 50/60 Hz
Connection		SINGLE PHASE
Cooking chamber dimension		(W)700 x (D)500 x (H)550 mm.
External dimension		(W)880 x (D)935 x (H)1060 mm.
Distance between trays		80 mm.
<b>RRP</b>		
Change opening door		
Automatic washing system		Included
Core Prober		Included
Natural gas		Under request
Chimney diameter		ø 150 mm.

# ST 610

REF. 710296



10 x 600 x 400

10 x GN 1/1

# ST 610 GAS

REF. 710323



10 x 600 x 400



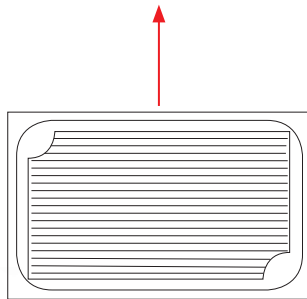

10 x GN 1/1







## EQUIPMENT

- Cycle end alarm
- Door safety switch
- Safety thermostat
- Halogen chamber light
- Water connection 3/4
- Folding inner glass for cleaning
- Reversing gear
- Double speed fan
- Timer 0-120 min. + continuous mode
- Adjustable humidity 0-100%

### FEATURES

Power		15.750 W
Max temperature		250° C
Weight		124 Kg.
Voltage		400 V - 50/60 Hz
Connection		Three phase 3F + N + T
Cooking chamber dimension		(W)700 x (D)500 x (H)870 mm.
External dimension		(W)880 x (D)935 x (H)1160 mm.
Distance between trays		80 mm.
<b>RRP</b>		
Change opening door		

### FEATURES

Power		600 W
Gas power		18 kW_15840 Kcal/h
Max temperature		250° C
Weight		140 Kg.
Voltage		230 V - 50/60 Hz
Connection		SINGLE PHASE
Cooking chamber dimension		(W)700 x (D)500 x (H)870 mm.
External dimension		(W)880 x (D)935 x (H)1350 mm.
Distance between trays		80 mm.
<b>RRP</b>		
Change opening door		
Natural gas		Under request
Chimney diameter		ø 150 mm.

# ST 610 V7

REF. 710322



10 x 600 x 400

10 x GN 1/1

# ST 610 V7 GAS

REF. 710324



10 x 600 x 400

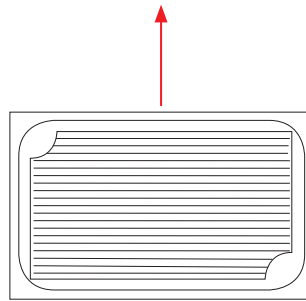

10 x GN 1/1







## EQUIPMENT

- Climate Control-adjustable humidity
- Fan Control-adjustable speed
- Steam Control-adjustable chimney
- Delta T
- External Core Probe connection
- Cooking phases
- Regeneration / Maintenance
- Recipe book
- Favorites
- Cool Down / Preheat
- Cycle end alarm
- Door sensor
- Safety thermostat
- LED chamber light
- Water connection 3/4
- Folding inner glass for cleaning
- Reversing gear
- USB port
- HACCP
- Multi Level

### FEATURES

Power		15.750 W
Max temperature		270° C
Weight		129 Kg.
Voltage		400 V - 50/60 Hz
Connection		Three phase 3F + N + T
Cooking chamber dimension		(W)700 x (D)500 x (H)870 mm.
External dimension		(W)880 x (D)935 x (H)1160 mm.
Distance between trays		80 mm.
<b>RRP</b>		
Change opening door		
Automatic washing system		Included
Core Prober		Included

### FEATURES

Power		600 W
Gas power		18 kW_15840 Kcal/h
Max temperature		270° C
Weight		145 Kg.
Voltage		230 V - 50/60 Hz
Connection		SINGLE PHASE
Cooking chamber dimension		(W)700 x (D)500 x (H)870 mm.
External dimension		(W)880 x (D)935 x (H)1350 mm.
Distance between trays		80 mm.
<b>RRP</b>		
Change opening door		
Automatic washing system		Included
Core Prober		Included
Natural gas		Under request
Chimney diameter		ø 150 mm.



NEW

**ST 721**

REF. 710414



7 x GN 2/1

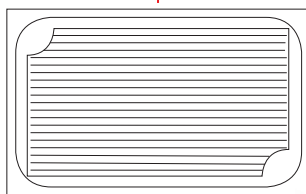

**ST 1221**

REF. 710420







12 x GN 2/1





EQUIPMENT

- Cycle end alarm
- Door safety switch
- Safety thermostat
- Halogen chamber light
- Water connection 3/4"
- Folding inner glass for cleaning
- Reversing gear
- Double speed fan
- Timer 0-120 min. + continuous mode
- Adjustable humidity 0-100%

FEATURES

Power		18.500 W
Max temperature		250° C
Weight		118 Kg.
Voltage		400 V - 50/60 Hz
Connection		Three phase 3F + N + T
Cooking chamber dimension		(W)700 x (D)744 x (H)550 mm.
External dimension		(W)880 x (D)1227 x (H)870 mm.
Distance between trays		70 mm.
<b>RRP</b>		
Change opening door		

FEATURES

Power		27.750 W
Max temperature		250° C
Weight		162 Kg.
Voltage		400 V - 50/60 Hz
Connection		Three phase 3F + N + T
Cooking chamber dimension		(W)700 x (D)744 x (H)870 mm.
External dimension		(W)880 x (D)1227 x (H)1160 mm.
Distance between trays		70 mm.
<b>RRP</b>		
Change opening door		

# ST 721 V7

REF. 710418

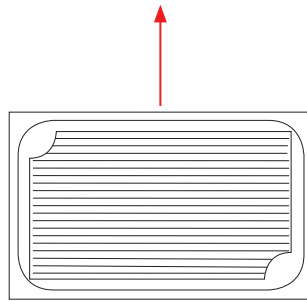

# ST 1221 V7

REF. 710419

**NEW**



7 x GN 2/1



12 x GN 2/1

## EQUIPMENT

- Climate Control-adjustable humidity
- Fan Control-adjustable speed
- Steam Control-adjustable chimney
- Delta T
- External Core Probe connection
- Cooking phases
- Regeneration / Maintenance
- Recipe book
- Favorites
- Cool Down / Preheat
- Cycle end alarm
- Door sensor
- Safety thermostat
- LED chamber light
- Water connection ¾
- Folding inner glass for cleaning
- Reversing gear
- USB port
- HACCP
- Multi Level

### FEATURES

Power		18.500 W
Max temperature		270° C
Weight		124 Kg.
Voltage		230 V - 50/60 Hz
Connection		SINGLE PHASE
Cooking chamber dimension		(W)700 x (D)744 x (H)550 mm.
External dimension		(W)880 x (D)1227 x (H)870 mm.
Distance between trays		70 mm.
<b>RRP</b>		
Change opening door		
Automatic washing system		Included
Core Prober		Included

### FEATURES

Power		27.750 W
Max temperature		270° C
Weight		170 Kg.
Voltage		230 V - 50/60 Hz
Connection		SINGLE PHASE
Cooking chamber dimension		(W)700 x (D)744 x (H)870 mm.
External dimension		(W)880 x (D)1227 x (H)1160 mm.
Distance between trays		70 mm.
<b>RRP</b>		
Change opening door		
Automatic washing system		Included
Core Prober		Included

# ST 616 V7

REF. 710325





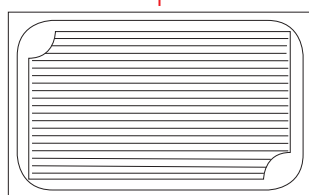

16 x 600 x 400



## EQUIPMENT

- Climate Control-adjustable humidity
- Fan Control-Fan Control-adjustable speed
- Steam Control-adjustable chimney
- Delta T
- Cooking phases
- Regeneration / Maintenance
- Recipe book
- Favorites
- Cool Down / Preheat
- Cycle end alarm
- Door sensor
- Safety thermostat
- LED chamber light
- Water connection 3/4
- Folding inner glass for cleaning
- Reversing gear
- USB port
- External Core Probe connection
- HACCP
- Multi Level

## FEATURES

Capacity		16 x 600 x 400 - 16 x GN 1/1
Power		28.750 W
Max temperature		270° C
Weight		206 Kg.
Voltage		400 V - 50/60 Hz
Connection		Three phase 3F + N + T
Cooking chamber dimension		(W)700 x (D)500 x (H)1470 mm.
External dimension		(W)880 x (D)960 x (H)1865 mm.
Distance between trays		80 mm.
<b>RRP</b>		
Change opening door		
Automatic washing system		Included
Core Prober		Included

# ST 616 V7 GAS

REF. 710326

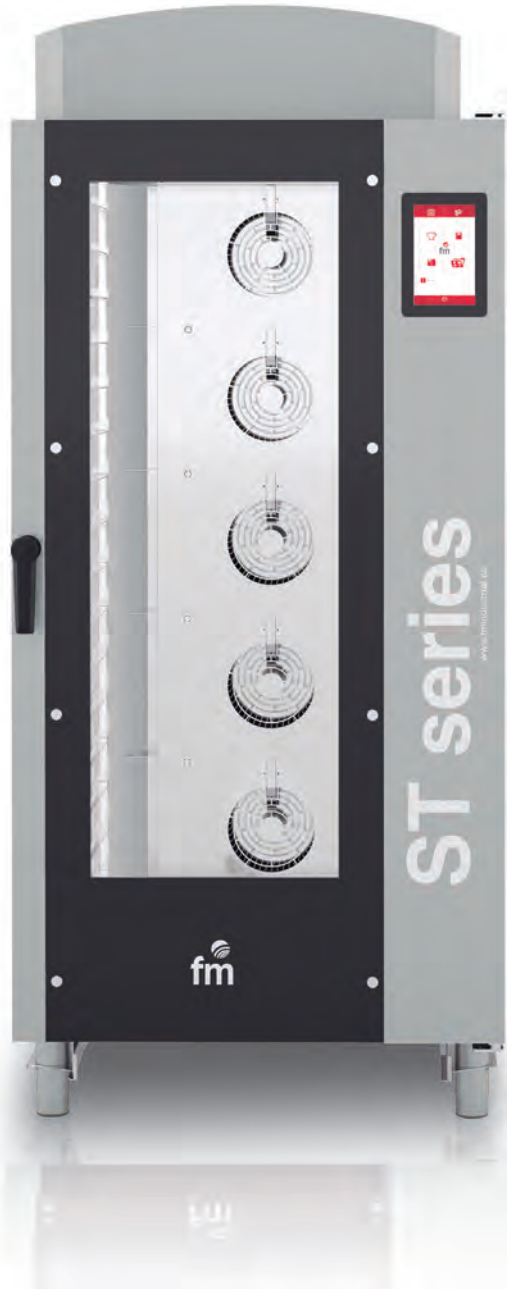



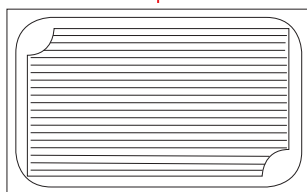

16 x 600 x 400



## EQUIPMENT

- Climate Control-adjustable humidity
- Fan Control-Fan Control-adjustable speed
- Steam Control-adjustable chimney
- Delta T
- Cooking phases
- Regeneration / Maintenance
- Recipe book
- Favorites
- Cool Down / Preheat
- Cycle end alarm
- Door sensor
- Safety thermostat
- LED chamber light
- Water connection 3/4
- Folding inner glass for cleaning
- Reversing gear
- USB port
- External Core Probe connection
- HACCP
- Multi Level

## FEATURES

Capacity		16 x 600 x 400 - 16 x GN 1/1
Power		1.000 W
Gas power		33 kW_28380 Kcal/h
Max temperature		270° C
Weight		252 Kg.
Voltage		230 V - 50/60 Hz
Connection		SINGLE PHASE
Cooking chamber dimension		(W)700 x (D)500 x (H)1470 mm.
External dimension		(W)880 x (D)1000 x (H)2055 mm.
Distance between trays		80 mm.
<b>RRP</b>		
Change opening door		
Automatic washing system		Included
Core Prober		Included
Natural gas		Under request
Chimney diameter		ø 180 mm.

STANDS PORTATRAYS FIJOS

TROLLEY PORTATRAYS EXTRAIBLE INCLUIDO

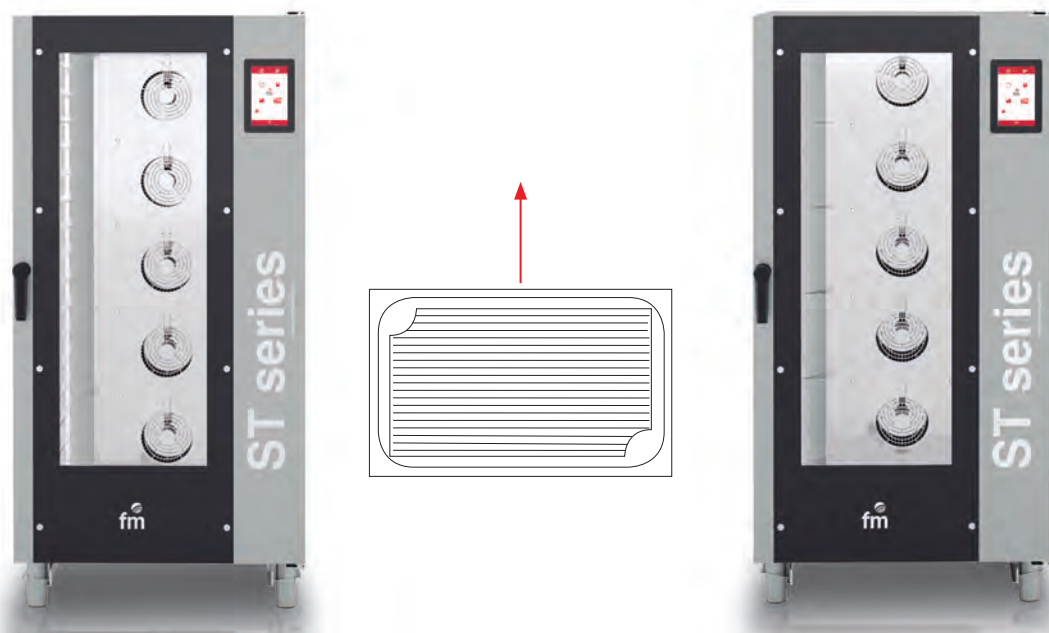

## EQUIPMENT

- Climate Control-adjustable humidity
- Fan Control-Fan Control-adjustable speed
- Steam Control-adjustable chimney
- Delta T
- External Core Probe connection
- 6 Cooking phases
- Regeneration / Maintenance
- Recipe book
- Favorites
- Cool Down / Preheat
- Cycle end alarm
- Door sensor
- Safety thermostat
- LED chamber light
- Water connection 3/4
- Folding inner glass for cleaning
- Reversing gear
- USB port
- HACCP
- Multi Level

FEATURES	<b>ST-616-V7-T</b> Ref. 710297	<b>ST-211-V7</b> Ref. 710329	<b>ST-211-V7-T</b> Ref. 710330	<b>ST-221-V7</b> Ref. 710333	<b>ST-221-V7-T</b> Ref. 710334
Capacity	16 x 600 x 400	20 x Gn 1/1	20 x Gn 1/1	20 x Gn 2/1 40 x Gn 1/1	20 x Gn 2/1 40 x Gn 1/1
Power	28.750 W	28.750 W	28.750 W	46.250 W	46.250 W
Gas power	-	-	-	-	-
Max temperature	270° C	270° C	270° C	270° C	270° C
Weight	198 Kg.	206 Kg.	206 Kg.	244 Kg.	232 Kg.
Voltage	400 V - 50/60 Hz	400 V - 50/60 Hz	400 V - 50/60 Hz	400 V - 50/60 Hz	400 V - 50/60 Hz
Connection	Three phase 3F + N + T	Three phase 3F + N + T	Three phase 3F + N + T	Three phase 3F + N + T	Three phase 3F + N + T
Cooking chamber dimension	(W)700x(D)500x(H)1470 mm.	(W)700x(D)500x(H)1470 mm.	(W)700x(D)500x(H)1470 mm.	(W)700x(D)740x(H)1470 mm.	(W)700x(D)740x(H)1470 mm.
External dimension	(W)880x(D)960x(H)1850 mm.	(W)880x(D)960x(H)1865 mm.	(W)880x(D)960x(H)1865 mm.	(W)880x(D)1200x(H)1865 mm.	(W)880x(D)1200x(H)1865 mm.
Distance between trays	80 mm.	65 mm.	65 mm.	65 mm.	65 mm.
<b>RRP</b>					
Change opening door					
Automatic washing system	Included	Included	Included	Included	Included
Core Prober	Included	Included	Included	Included	Included
Natural gas	-	-	-	-	-
Chimney diameter	-	-	-	-	-
Trolley	✓	✗	✓	✗	✓



STANDS PORTATRAYS FIJOS

TROLLEY PORTATRAYS EXTRAIBLE INCLUIDO

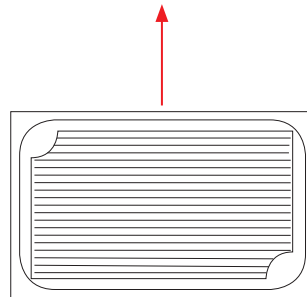

## EQUIPMENT

- Climate Control-adjustable humidity
- Fan Control-Fan Control-adjustable speed
- Steam Control-adjustable chimney
- Delta T
- External Core Probe connection
- 6 Cooking phases
- Regeneration / Maintenance
- Recipe book
- Favorites
- Cool Down / Preheat
- Cycle end alarm
- Door sensor
- Safety thermostat
- LED chamber light
- Water connection  $\frac{3}{4}$
- Folding inner glass for cleaning
- Reversing gear
- USB port
- HACCP
- Multi Level

FEATURES	<b>ST-616-V7-GAS-T</b> Ref. 710303	<b>ST-211-V7-GAS</b> Ref. 710331	<b>ST-211-V7-GAS-T</b> Ref. 710332	<b>ST-221-V7-GAS</b> Ref. 710335	<b>ST-221-V7-GAS-T</b> Ref. 710336
Capacity	16 x 600 x 400	20 x Gn 1/1	20 x Gn 1/1	20 x Gn 2/1 40 x Gn 1/1	20 x Gn 2/1 40 x Gn 1/1
Power	1.000 W	1.000 W	1.000 W	1.000 W	1.000 W
Gas power	33 Kw_28380 Kcal/h	33 Kw_28380 Kcal/h	33 Kw_28380 Kcal/h	50 Kw_43000 Kcal/h	50 Kw_43000 Kcal/h
Max temperature	270° C	270° C	270° C	270° C	270° C
Weight	244 Kg.	252 Kg.	244 Kg.	300 Kg.	288 Kg.
Voltage	230 V - 50/60 Hz	230 V - 50/60 Hz	230 V - 50/60 Hz	230 V - 50/60 Hz	230 V - 50/60 Hz
Connection	Shuko SINGLE PHASE	Shuko SINGLE PHASE	Shuko SINGLE PHASE	Shuko SINGLE PHASE	Shuko SINGLE PHASE
Cooking chamber dimension	(W)700x(D)500x(H)1470 mm.	(W)700x(D)500x(H)1470 mm.	(W)700x(D)500x(H)1470 mm.	(W)700x(D)740x(H)1470 mm.	(W)700x(D)740x(H)1470 mm.
External dimension	(W)880x(D)1000x(H)2055 mm.	(W)880x(D)1000x(H)2055 mm.	(W)880x(D)1000x(H)2055 mm.	(W)880x(D)1240x(H)2055mm.	(W)880x(D)1240x(H)2055mm.
Distance between trays	80 mm.	65 mm.	65 mm.	65 mm.	65 mm.
<b>RRP</b>					
Change opening door					
Automatic washing system	Included	Included	Included	Included	Included
Core Prober	Included	Included	Included	Included	Included
Natural gas	Under request	Under request	Under request	Under request	Under request
Chimney diameter	ø 180 mm.	ø 180 mm.	ø 180 mm.	ø 200 mm.	ø 200 mm.
Trolley	✓	✗	✓	✗	✓

# COMPOSITION ST

*Hood ST + ST 606 V7 + Stand ST 650*

BAKERY



HOSTELRY

# CONTROL PANEL

NEW

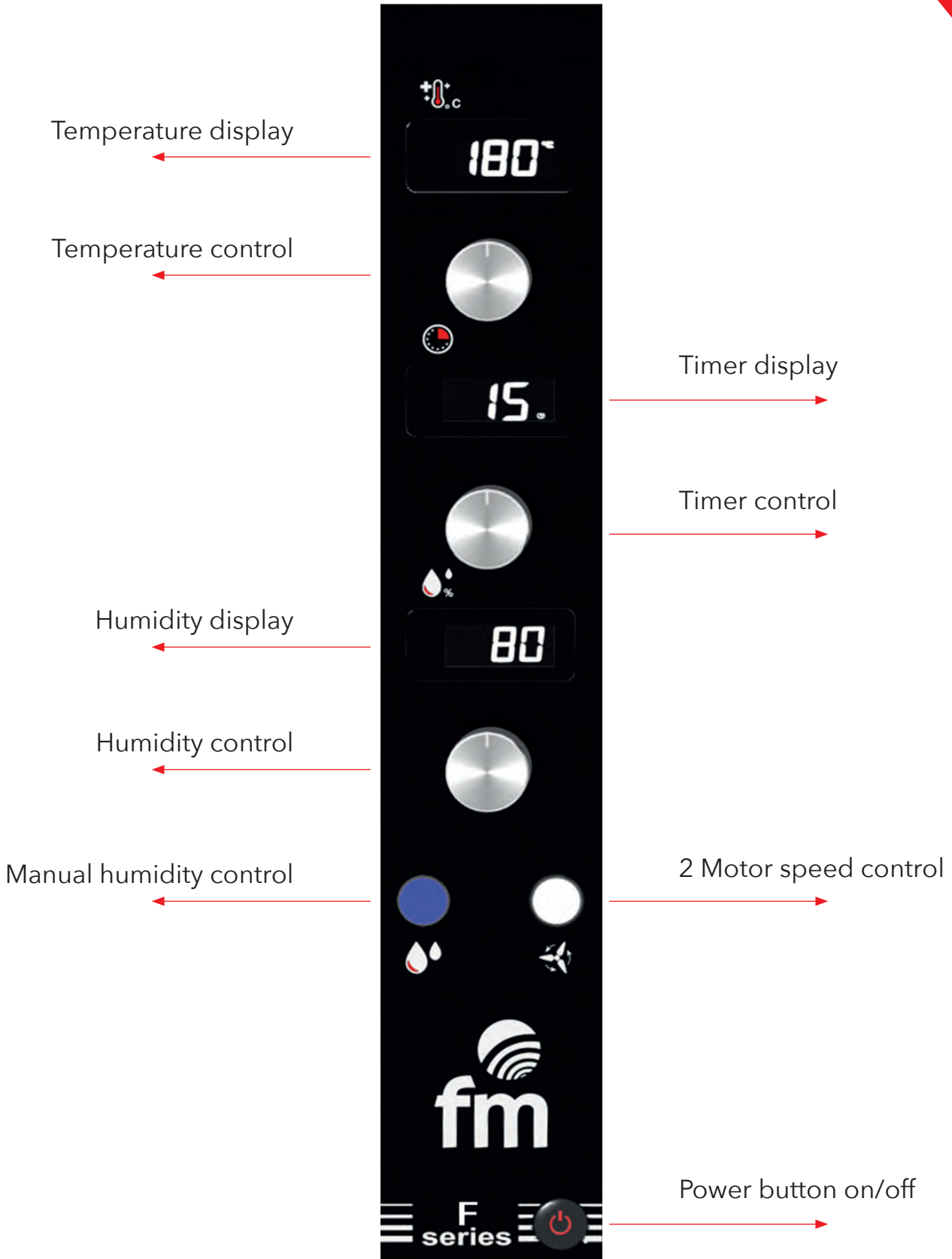







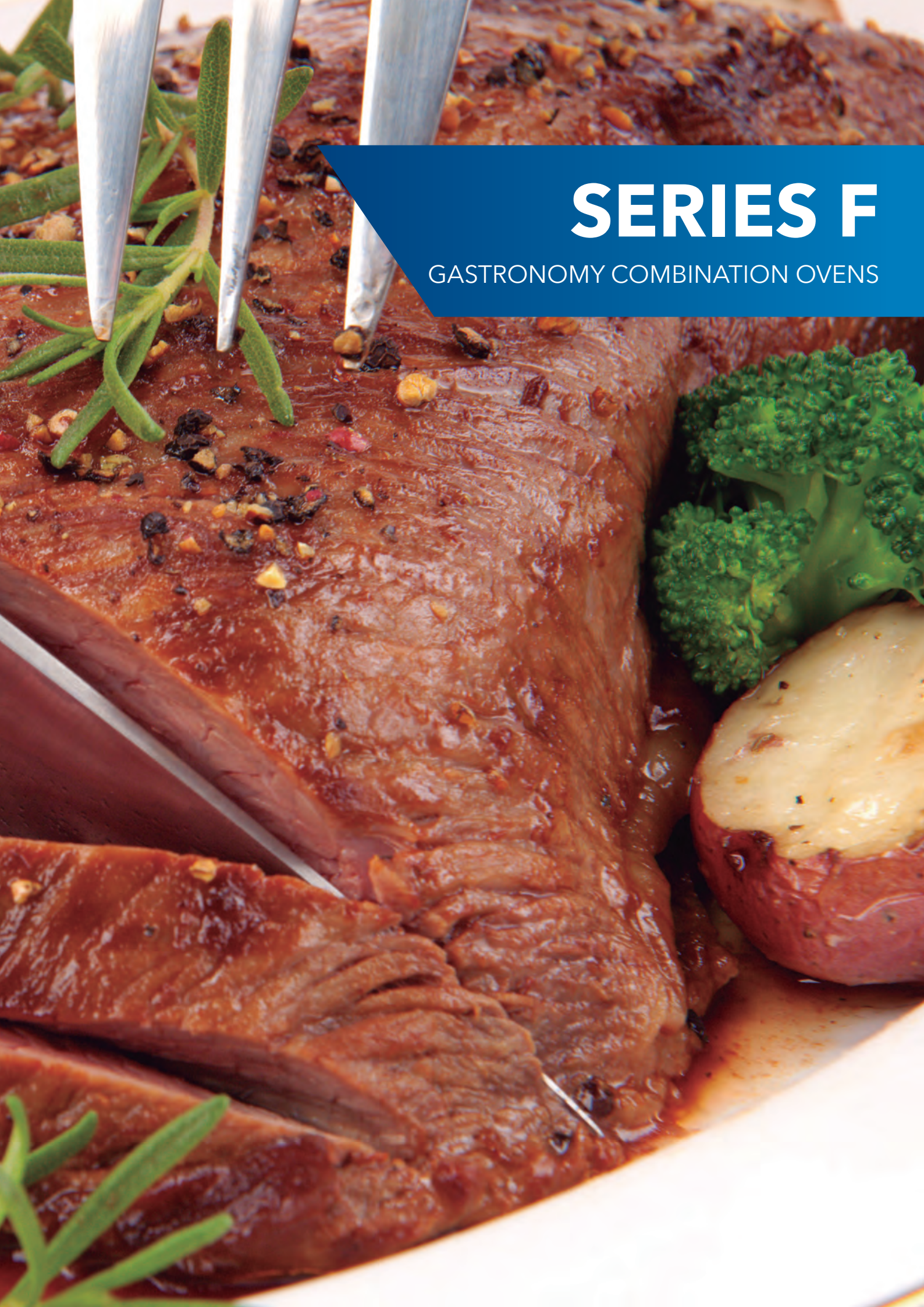

# SERIES F

GASTRONOMY COMBINATION OVENS



# F 104

REF. 710012

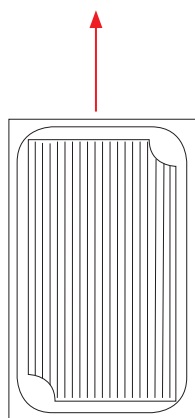





4 x GN 2/3

## EQUIPMENT

- Cycle end alarm
- Door safety switch
- Safety thermostat
- Manual chimney control
- LED chamber light
- Water connection 3/4
- Folding inner glass for cleaning
- Reversing gear
- Timer 0-120 min. + continuous mode
- Adjustable humidity 0-100%

## FEATURES

Capacity		4 x GN 2/3
Power		5.150 W
Max temperature		250° C
Weight		52 Kg.
Voltage		400 / 230 V - 50/60 Hz
Connection		Three phase 3F + N + T
Cooking chamber dimension		(W)380 x (D)380 x (H)365 mm.
External dimension		(W)650 x (D)715 x (H)600 mm.
Distance between trays		65 mm.
<b>RRP</b>		
Change opening door		

# F 106

REF. 710013

# F 110

REF. 710014



6 x GN 1/1

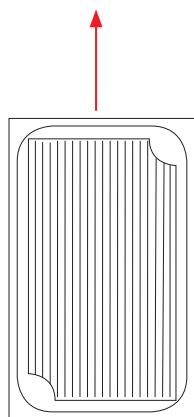

10 x GN 1/1

## EQUIPMENT

- Cycle end alarm
- Door safety switch
- Safety thermostat
- Manual chimney control
- LED chamber light
- Water connection  $\frac{3}{4}$
- Folding inner glass for cleaning
- Reversing gear
- Timer 0-120 min. + continuous mode
- Adjustable humidity 0-100%

### FEATURES

Capacity	6 x GN 1/1
Power	 9.200 W
Max temperature	 250° C
Weight	 65 Kg.
Voltage	 400 / 230 V - 50/60 Hz
Connection	Three phase 3F + N + T
Cooking chamber dimension	(W)395 x (D)590 x (H)480 mm.
External dimension	(W)660 x (D)825 x (H)780 mm.
Distance between trays	65 mm.
<b>RRP</b>	
Change opening door	

### FEATURES

Capacity	10 x GN 1/1
Power	 15.400 W
Max temperature	 250° C
Weight	 97 Kg.
Voltage	 400 V - 50/60 Hz
Connection	Three phase 3F + N + T
Cooking chamber dimension	(W)395 x (D)590 x (H)810 mm.
External dimension	(W)660 x (D)825 x (H)1020 mm.
Distance between trays	65 mm.
<b>RRP</b>	
Change opening door	

**F 106 E**

REF. 710427

**F 110 E**

REF. 710428

**NEW**



6 x GN 1/1

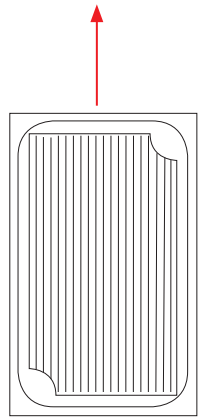





10 x GN 1/1





EQUIPMENT

- Cycle end alarm
- Door safety switch
- Safety thermostat
- LED chamber light
- Water connection 3/4
- Folding inner glass for cleaning
- Reversing gear
- Double fan speed
- Timer 0-120 min. + continuous mode
- Manual chimney control
- Adjustable humidity 0-100%

FEATURES

Power		9.200 W
Max temperature		250° C
Weight		65 Kg.
Voltage		400 / 230 V - 50/60 Hz
Connection		Three phase 3F + N + T
Cooking chamber dimension		(W)395 x (D)590 x (H)480 mm.
External dimension		(W)660 x (D)825 x (H)780 mm.
Distance between trays		65 mm.
<b>RRP</b>		
Change opening door		

FEATURES

Power		15.400 W
Max temperature		250° C
Weight		97 Kg.
Voltage		400 V - 50/60 Hz
Connection		Three phase 3F + N + T
Cooking chamber dimension		(W)395 x (D)590 x (H)811 mm.
External dimension		(W)660 x (D)825 x (H)1110 mm.
Distance between trays		65 mm.
<b>RRP</b>		
Change opening door		

# F 106 V7

REF. 710255



6 x GN 1/1

# F 110 V7

REF. 710190



10 x GN 1/1

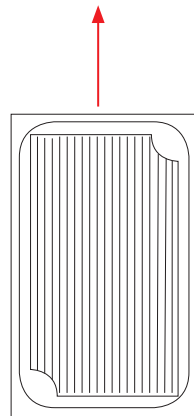

## EQUIPMENT

- Climate Control-adjustable humidity
- Fan Control-adjustable speed
- Steam Control-adjustable chimney
- Delta T
- Core Prober
- 6 Cooking phases
- Regeneration / Maintenance
- Recipe book
- Favorites
- Cool Down / Preheat
- Cycle end alarm
- Door safety switch
- Safety thermostat
- LED chamber light
- Water connection 3/4"
- Folding inner glass for cleaning
- Reversing gear

## FEATURES

Power		9.200 W
Max temperature		270° C
Weight		80 Kg.
Voltage		400 V - 50/60 Hz
Connection		Three phase 3F + N + T
Cooking chamber dimension		(W)395 x (D)590 x (H)480 mm.
External dimension		(W)725 x (D)815 x (H)690 mm.
Distance between trays		65 mm.
<b>RRP</b>		
Change opening door		
Automatic washing system		700 €
Core Prober		Included

## FEATURES

Power		15.400 W
Max temperature		270° C
Weight		97 Kg.
Voltage		400 V - 50/60 Hz
Connection		Three phase 3F + N + T
Cooking chamber dimension		(W)395 x (D)590 x (H)810 mm.
External dimension		(W)725 x (D)815 x (H)1020 mm.
Distance between trays		65 mm.
<b>RRP</b>		
Change opening door		
Automatic washing system		
Core Prober		Included



# SERIES RXB

MIXED OVENS







# RXB 606

REF. 710084



6 x 600 x 400

6 x GN 1/1

## EQUIPMENT

- Cycle end alarm
- Door safety switch
- Safety thermostat
- LED chamber light
- Water connection ¾
- Manual chimney control
- Folding inner glass for cleaning
- Reversing gear
- Timer 0-120 min. Continuous mode
- Adjustable humidity 0-100%

# RXB 606 E

REF. 710425



6 x 600 x 400



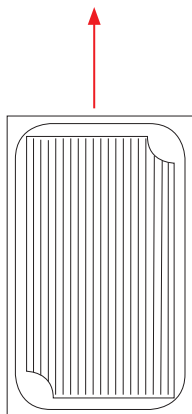

6 x GN 1/1

## EQUIPMENT





- Cycle end alarm
- Door safety switch
- Safety thermostat
- LED chamber light
- Water connection ¾
- Double fan speed
- Adjustable humidity 0-100%
- Folding inner glass for cleaning
- Reversing gear
- Timer 0-120 min. Continuous mode
- Manual chimney control



## FEATURES

Power		9.100 W
Max temperature		250° C
Weight		90 Kg.
Voltage		400 V - 50/60 Hz
Connection		Three phase 3F + N + T
Cooking chamber dimension		(W)490 x (D)655 x (H)630 mm.
External dimension		(W)755 x (D)880 x (H)930 mm.
Distance between trays		80 mm.
<b>RRP</b>		
Change opening door		

## FEATURES

Power		9.100 W
Max temperature		250° C
Weight		90 Kg.
Voltage		400 V - 50/60 Hz
Connection		Three phase 3F + N + T
Cooking chamber dimension		(W)490 x (D)655 x (H)630 mm.
External dimension		(W)755 x (D)880 x (H)930 mm.
Distance between trays		80 mm.
<b>RRP</b>		
Change opening door		

# RXB 606 V7

REF. 710186

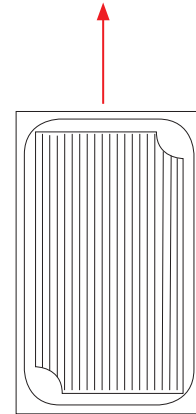





6 x 600 x 400

6 x GN 1/1

## EQUIPMENT

- Climate Control-adjustable humidity
- Fan Control-Fan Control-adjustable speed
- Steam Control-adjustable chimney
- Delta T
- Opcional: Core Prober
- Cooking phases
- Regeneration / Maintenance
- Recipe book
- Favorites
- Cool Down / Preheat
- Cycle end alarm
- Door safety switch
- Safety thermostat
- LED chamber light
- Water connection ¾
- Folding inner glass for cleaning
- Reversing gear

## FEATURES

Power		9.100 W
Max temperature		270° C
Weight		92 Kg.
Voltage		400 V - 50/60 Hz
Connection		Three phase 3F + N + T
Cooking chamber dimension		(W)490 x (D)655 x (H)630 mm.
External dimension		(W)815 x (D)880 x (H)930 mm.
Distance between trays		80 mm.
<b>RRP</b>		
Change opening door		
Automatic washing system		
Core Prober		



# RXB 606 GAS

REF. 710253

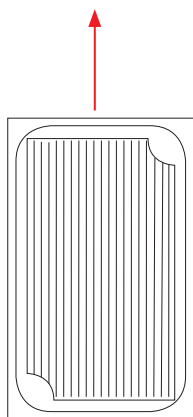





6 x 600 x 400

6 x GN 1/1

## EQUIPMENT

- Cycle end alarm
- Door safety switch
- Safety thermostat
- Manual chimney control
- LED chamber light
- Water connection 3/4
- Folding inner glass for cleaning
- Reversing gear
- Timer 0-120 min. + continuous mode
- Adjustable humidity 0-100%

## FEATURES

Power		400 W
Gas power		13,5 kW_11620 Kcal/h
Max temperature		250° C
Weight		104 Kg.
Voltage		220 V - 50/60 Hz
Connection		SINGLE PHASE
Cooking chamber dimension		(W)490 x (D)655 x (H)630 mm.
External dimension		(W)815 x (D)880 x (H)1090 mm.
Distance between trays		80 mm.
<b>RRP</b>		
Change opening door		
Natural gas		Under request
Chimney diameter		ø 150 mm.

# RXB 606 V7 GAS

REF. 710314

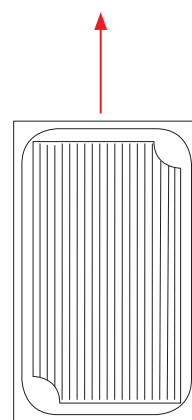





6 x 600 x 400

6 x GN 1/1

## EQUIPMENT

- Climate Control-adjustable humidity
- Fan Control-adjustable speed
- Steam Control-adjustable chimney
- Delta T
- Opción Core Prober
- 6 Cooking phases
- Regeneration / Maintenance
- Recipe book
- Favorites
- Cool Down / Preheat
- Cycle end alarm
- Door safety switch
- Safety thermostat
- LED chamber light
- Water connection 3/4
- Folding inner glass for cleaning
- Reversing gear

## FEATURES

Power		400 W
Gas power		13,5 kW_11620 Kcal/h
Max temperature		270° C
Weight		104 Kg.
Voltage		230 V - 50/60 Hz
Connection		SINGLE PHASE
Cooking chamber dimension		(W)490 x (D)655 x (H)630 mm.
External dimension		(W)815 x (D)880 x (H)1090 mm.
Distance between trays		80 mm.
<b>RRP</b>		
Change opening door		
Automatic washing system		
Core Prober		
Natural gas		Under request
Chimney diameter		ø 150 mm.

# RXB 610

REF. 710085







10 x 600 x 400

10 x GN 1/1

## EQUIPMENT

- Cycle end alarm
- Door safety switch
- Safety thermostat
- LED chamber light
- Water connection ¾
- Folding inner glass for cleaning
- Reversing gear
- Timer 0-120 min. + continuous mode
- Adjustable humidity 0-100%

## FEATURES

Power		13.650 W
Max temperature		250° C
Weight		109 Kg.
Voltage		400 V - 50/60 Hz
Connection		Three phase 3F + N + T
Cooking chamber dimension		(W)490 x (D)655 x (H)935 mm.
External dimension		(W)755 x (D)880 x (H)1235 mm.
Distance between trays		80 mm.
<b>RRP</b>		
Change opening door		

# RXB 610 E

REF. 710426







10 x 600 x 400

10 x GN 1/1

## EQUIPMENT

- Cycle end alarm
- Door safety switch
- Safety thermostat
- LED chamber light
- Water connection ¾
- Folding inner glass for cleaning
- Reversing gear
- Timer 0-120 min. + continuous mode
- Adjustable humidity 0-100%
- Double fan speed
- Manual chimney control

## FEATURES

Power		13.800 W
Max temperature		250° C
Weight		109 Kg.
Voltage		400 V - 50/60 Hz
Connection		Three phase 3F + N + T
Cooking chamber dimension		(W)490 x (D)655 x (H)935 mm.
External dimension		(W)755 x (D)880 x (H)1235 mm.
Distance between trays		80 mm.
<b>RRP</b>		
Change opening door		

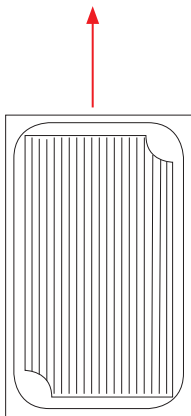

# RXB 610 V7

REF. 710362

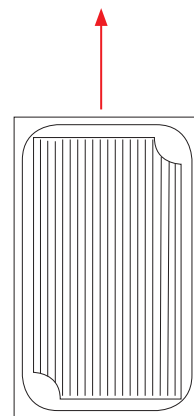



10 x 600 x 400

10 x GN 1/1

## EQUIPMENT

- Climate Control-adjustable humidity
- Fan Control-adjustable speed
- Steam Control-adjustable chimney
- Delta T
- Opcional: Core Prober
- 6 Cooking phases
- Regeneration / Maintenance
- Recipe book
- Favorites
- Cool Down / Preheat
- Cycle end alarm
- Door safety switch
- Safety thermostat
- LED chamber light
- Water connection ¾
- Folding inner glass for cleaning
- Reversing gear

## FEATURES

Power		13.650 W
Max temperature		270° C
Weight		112 Kg.
Voltage		400 V - 50/60 Hz
Connection		Three phase 3F + N + T
Cooking chamber dimension		(W)490 x (D)655 x (H)935 mm.
External dimension		(W)815 x (D)880 x (H)1235 mm.
Distance between trays		80 mm.
<b>RRP</b>		
Change opening door		
Automatic washing system		
Core Prober		



# RXB 610 GAS

REF. 710185

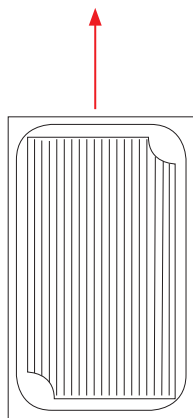





10 x 600 x 400

10 x GN 1/1

## EQUIPMENT

- Cycle end alarm
- Door safety switch
- Safety thermostat
- Manual chimney control
- LED chamber light
- Water connection 3/4
- Folding inner glass for cleaning
- Reversing gear
- Timer 0-120 min. + continuous mode
- Adjustable humidity 0-100%

## FEATURES

Power		600 W
Gas power		18 kW_15480 Kcal/h
Max temperature		250° C
Weight		127 Kg.
Voltage		230 V - 50/60 Hz
Connection		SINGLE PHASE
Cooking chamber dimension		(W)490 x (D)655 x (H)935 mm.
External dimension		(W)815 x (D)880 x (H)1395 mm.
Distance between trays		80 mm.
<b>RRP</b>		
Change opening door		
Natural gas		Under request
Chimney diameter		ø 150 mm.

# RXB 610 V7 GAS

REF. 710315



10 x 600 x 400



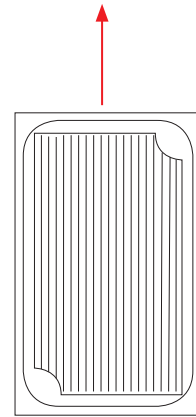

10 x GN 1/1



## EQUIPMENT

- Climate Control-adjustable humidity
- Fan Control-adjustable speed
- Steam Control-adjustable chimney
- Delta T
- Opción Core Prober
- 6 Cooking phases
- Regeneration / Maintenance
- Recipe book
- Favorites
- Cool Down / Preheat
- Cycle end alarm
- Door safety switch
- Safety thermostat
- LED chamber light
- Water connection 3/4
- Folding inner glass for cleaning
- Reversing gear

## FEATURES

Power		600 W
Gas power		18 kW_15480 Kcal/h
Max temperature		270° C
Weight		127 Kg.
Voltage		230 V - 50/60 Hz
Connection		SINGLE PHASE
Cooking chamber dimension		(W)490 x (D)655 x (H)935 mm.
External dimension		(W)815 x (D)880 x (H)1395 mm.
Distance between trays		80 mm.
<b>RRP</b>		
Change opening door		
Automatic washing system		
Core Prober		
Natural gas		Under request
Chimney diameter		ø 150 mm.



# **SERIES RX**

CONVECTION OVENS







# RX 203

REF. 710293







3 x 340 x 240

3 x GN 1/2

## EQUIPMENT

- Safety thermostat
- Timer 0-60 min. Continuous mode

## FEATURES

Capacity		3 x 340 x 240 - 3 x GN 1/2
Power		2.250 W
Max temperature		250° C
Weight		22 Kg.
Voltage		230 V - 50 Hz
Endowment		3 perforated aluminium tray
Connection		SINGLE PHASE
Cooking chamber dimension		(W)360 x (D)290 x (H)260 mm.
External dimension		(W)500 x (D)560 x (H)455 mm.
<b>RRP</b>		
Humidifier Ref. 710313		

# RX 304

REF. 710040







4 x 430 x 340

## EQUIPMENT

- Safety thermostat
- Timer 0-60 min. Continuous mode

## FEATURES

Capacity		4 x 430 x 340
Power		3.100 W
Max temperature		250° C
Weight		34 Kg.
Voltage		230 V - 50 Hz
Endowment		4 perforated aluminium tray
Connection		SINGLE PHASE
Cooking chamber dimension		(W)450 x (D)340 x (H)345 mm.
External dimension		(W)590 x (D)675 x (H)540 mm.
Distance between trays		80 mm.
<b>RRP RX-304</b>		
GRILL 1,4 kW		
Humidifier		
Kit GN 2/3		
RRP RXL-304 Ref. 710088		

# RX 384

REF. 710178





4 x 430 x 340

## EQUIPMENT

- Cycle end alarm
- Door safety switch
- Safety thermostat
- Halogen chamber light
- Timer 0-60 min. Continuous mode

## FEATURES

Capacity		4 x 430 x 340
Power		3.200 W
Max temperature		250° C
Weight		35 Kg.
Voltage		230 V - 50/60 Hz
Endowment		4 perforated aluminium tray
Connection		SINGLE PHASE
Cooking chamber dimension		(W)450 x (D)370 x (H)345 mm.
External dimension		(W)590 x (D)700 x (H)540 mm.
Distance between trays		80 mm.
<b>RRP RX-384</b>		
GRILL 1,4 kW		
Humidifier		
Kit GN 2/3		
RRP RXL-384 Ref. 710204		

# RX 424

REF. 710018





4 x 480 x 340

## EQUIPMENT

- Cycle end alarm
- Safety thermostat
- Halogen chamber light
- Timer 0-60 min. Continuous mode

## FEATURES

Capacity		4 x 480 x 340
Power		3.100 W
Max temperature		250° C
Weight		36 Kg.
Voltage		230 V - 50 Hz
Endowment		4 wire rack
Connection		SINGLE PHASE
Cooking chamber dimension		(W)500 x (D)410 x (H)345 mm.
External dimension		(W)640 x (D)720 x (H)540 mm.
Distance between trays		80 mm.
<b>RRP RX-424</b>		
GRILL 1,4 kW		
Humidifier		
Kit GN 2/3		
RRP RXL-424 Ref. 710071		



# RX 584

REF. 710267



4 x 480 x 440

## EQUIPMENT

- Cycle end alarm
- Door safety switch
- Safety thermostat
- Halogen chamber light
- Reversing gear
- Timer 0-60 min. Continuous mode

## FEATURES

Capacity		4 x 480 x 440
Power		3.700 W
Max temperature		250° C
Weight		39 Kg.
Voltage		230 V - 50/60 Hz
Endowment		4 wire rack
Connection		SINGLE PHASE
Cooking chamber dimension		(W)500 x (D)470 x (H)345 mm.
External dimension		(W)640 x (D)820 x (H)540 mm.
Distance between trays		80 mm.
<b>RRP RX-584</b>		
GRILL 1,4 kW		
Humidifier		
Kit GN 2/3		
RRP RXL-584 Ref. 710275		

# RX 603

REF. 710051



3 x 600 x 400

## EQUIPMENT

- Cycle end alarm
- Door safety switch
- Safety thermostat
- Halogen chamber light
- Reversing gear
- Timer 0-60 min. Continuous mode

## FEATURES

Capacity		3 x 600 x 400
Power		3.900 W
Max temperature		250° C
Weight		39Kg.
Voltage		230 V - 50/60 Hz
Endowment		3 wire rack
Connection		SINGLE PHASE
Cooking chamber dimension		(W)620 x (D)450 x (H)270 mm.
External dimension		(W)760 x (D)800 x (H)465 mm.
Distance between trays		80 mm.
<b>RRP RX-603</b>		
GRILL 1,4 kW		
Humidifier		
Kit GN 1/1		
RRP RXL-603 Ref. 710072		

# RX 604

REF. 710055







4 x 600 x 400

BAKERY

## EQUIPMENT

- Cycle end alarm
- Door safety switch
- Safety thermostat
- Halogen chamber light
- Reversing gear
- Timer 0-60 min. Continuous mode

## FEATURES

Capacity		4 x 600 x 400
Power		5.700 W
Max temperature		250° C
Weight		42 Kg.
Voltage		400 / 230 V - 50/60 Hz
Endowment		4 wire rack
Connection		Three phase 3F + N + T
Cooking chamber dimension		(W)620 x (D)450 x (H)350 mm.
External dimension		(W)760 x (D)800 x (H)545 mm.
Distance between trays		80 mm.
<b>RRP RX-604</b>		
GRILL		1,4 kW
Humidifier		
Kit GN 1/1		
Change to single phase		

# RX 604 PLUS

REF. 710056







4 x 600 x 400

## EQUIPMENT

- Cycle end alarm
- Door safety switch
- Safety thermostat
- Halogen chamber light
- Reversing gear
- Timer 0-60 min. Continuous mode

## FEATURES

Capacity		4 x 600 x 400
Power		6.300 W
Max temperature		250° C
Weight		48 Kg.
Voltage		400 / 230 V - 50/60 Hz
Endowment		4 wire rack
Connection		Three phase 3F + N + T
Cooking chamber dimension		(W)620 x (D)450 x (H)350 mm.
External dimension		(W)760 x (D)800 x (H)545 mm.
Distance between trays		80 mm.
<b>RRP RX-604-PLUS</b>		
GRILL 1,4 kW		
Humidifier		
Kit GN 1/1		
Change to single phase		
RRP RXL-604-PLUS Ref. 710073		



# SERIES M/ME





# ME 384

REF. 710175





4 x 430 x 340

## EQUIPMENT

- Adjustable humidity 0-100%
- Cooking phases
- Recipe book
- Cycle end alarm
- Door safety switch
- Safety thermostat
- Halogen chamber light
- Water connection  $\frac{3}{4}$
- Reversing gear
- Pre heating

## FEATURES

Capacity		4 x 430 x 340
Power		3.200 W
Max temperature		260° C
Weight		35 Kg.
Voltage		230 V - 50/60 Hz
Endowment		4 wire rack
Connection		SINGLE PHASE
Cooking chamber dimension		(W)450 x (D)370 x (H)345 mm.
External dimension		(W)590 x (D)700 x (H)540 mm.
Distance between trays		80 mm.
<b>RRP ME-384</b>		
Kit GN 2/3		
RRP ME-384-L Ref. 710213		

# M 603

REF. 710126







3 x 600 x 400

## EQUIPMENT

- Cycle end alarm
- Door safety switch
- Safety thermostat
- Halogen chamber light
- Reversing gear
- Timer 0-60 min. Continuous mode

## FEATURES

Capacity		3 x 600 x 400
Power		3.900 W
Max temperature		250° C
Weight		42 Kg.
Voltage		230 V - 50/60 Hz
Endowment		3 wire rack
Connection		SINGLE PHASE
Cooking chamber dimension		(W)680 x (D)450 x (H)280 mm.
External dimension		(W)820 x (D)800 x (H)475 mm.
Distance between trays		80 mm.
<b>RRP M-603</b>		
Humidifier		
RRP M-603-L ref. 710127		

# ME 603

REF. 710128







3 x 600 x 400

## EQUIPMENT

- Adjustable humidity 0-100%
- Recipe book
- Cycle end alarm
- Door safety switch
- Safety thermostat
- Halogen chamber light
- Water connection  $\frac{3}{4}$
- Reversing gear
- Pre heating

## FEATURES

Capacity		3 x 600 x 400
Power		3.900 W
Max temperature		260° C
Weight		42 Kg.
Voltage		230 V - 50/60 Hz
Endowment		3 wire rack
Connection		SINGLE PHASE
Cooking chamber dimension		(W)680 x (D)450 x (H)280 mm.
External dimension		(W)820 x (D)800 x (H)475 mm.
Distance between trays		80 mm.
<b>RRP ME-603</b>		
Kit GN 1/1		
RRP ME-603-L Ref. 710129		



# M 604 PLUS

REF. 710130





4 x 600 x 400

## EQUIPMENT

- Cycle end alarm
- Door safety switch
- Safety thermostat
- Halogen chamber light
- Reversing gear
- Timer 0-60 min. Continuous mode

## FEATURES

Capacity		4 x 600 x 400
Power		6.300 W
Max temperature		250° C
Weight		51 Kg.
Voltage		400 / 230 V - 50/60 Hz
Endowment		4 wire rack
Connection		Three phase 3F + N
Cooking chamber dimension		(W)680 x (D)450 x (H)360 mm.
External dimension		(W)820 x (D)800 x (H)555 mm.
Distance between trays		80 mm.
<b>RRP M-604-PLUS</b>		
Humidifier		
RRP M-604-PLUS-L Ref. 710131		
Change to single phase		

# ME 604 PLUS

REF. 710108







4 x 600 x 400

## EQUIPMENT

- Adjustable humidity 0-100%
- Recipe book
- Cycle end alarm
- Door safety switch
- Safety thermostat
- Halogen chamber light
- Water connection  $\frac{3}{4}$
- Reversing gear
- Pre heating

## FEATURES

Capacity		4 x 600 x 400
Power		6.300 W
Max temperature		260° C
Weight		51 Kg.
Voltage		400 / 230 V - 50/60 Hz
Endowment		4 wire rack
Connection		Three phase 3F + N
Cooking chamber dimension		(W)680 x (D)450 x (H)360 mm.
External dimension		(W)820 x (D)800 x (H)555 mm.
Distance between trays		80 mm.
<b>RRP ME-604-PLUS</b>		
Kit GN 1/1		
RRP ME-604-PLUS-L Ref. 710131		
Change to single phase		

# MP 603

REF. 710002



3 x 600 x 400

## EQUIPMENT

- Cycle end alarm
- Door safety switch
- Safety thermostat
- Halogen chamber light
- Timer 0-60 min. Continuous mode

## FEATURES

Capacity		3 x 600 x 400
Power		3.300 W
Max temperature		250° C
Weight		35 Kg.
Voltage		230 V - 50/60 Hz
Endowment		3 wire rack
Connection		SINGLE PHASE
Cooking chamber dimension		(W)620 x (D)450 x (H)270 mm.
External dimension		(W)760x (D)760 x (H)465 mm.
Distance between trays		80 mm.
<b>RRP</b>		
GRILL 2,2 kW		
Humidifier		
Kit GN 1/1		

# MP 604

REF. 710001



4 x 600 x 400

## EQUIPMENT

- Cycle end alarm
- Door safety switch
- Safety thermostat
- Halogen chamber light
- Timer 0-60 min. Continuous mode

## FEATURES

Capacity		4 x 600 x 400
Power		3.800 W
Max temperature		250° C
Weight		44 Kg.
Voltage		230 V - 50/60 Hz
Endowment		4 wire rack
Connection		SINGLE PHASE
Cooking chamber dimension		(W)620 x (D)450 x (H)350 mm.
External dimension		(W)760x (D)760 x (H)540 mm.
Distance between trays		80 mm.
<b>RRP</b>		
GRILL 2,2 kW		
Humidifier		
Kit GN 1/1		



**PROVER**



# F 408

REF. 730002



8 x 480 x 340

# F 608

REF. 730001





8 x 600 x 400



## EQUIPMENT

- Dry and wet heat control

### FEATURES

Power		700 W
Max temperature		85° C
Weight		32 Kg.
Voltage		230 V - 50/60 Hz
Connection		SINGLE PHASE
External dimension		(W)640 x (D)640 x (H)930 mm.
Distance between trays		80 mm.
<b>RRP</b>		

### FEATURES

Power		1400 W
Max temperature		85° C
Weight		42 Kg.
Voltage		230 V - 50/60 Hz
Connection		SINGLE PHASE
External dimension		(W)760 x (D)700 x (H)930 mm.
Distance between trays		80 mm.
<b>RRP</b>		



# TOASTERS



# TTH 4400

REF. 720009



NEW



## EQUIPMENT

- Adjustable speed regulator
- Removable bottom tray
- Height adjustment for cavity entry (Min. 30 / Max 70.)
- Double direction of rotation
- Upper tray warmer
- Food input and output tray
- Independent power element regulator

## FEATURES

Power		4.400 W
Weight		35 Kg.
Voltage		230 V - 50/60 Hz
Connection		Single phase
External dimension		(W)1258 x (D)575 x (H)335 mm.
Cooking chamber dimension		(W)335 x (D)555 x (H)70 mm.
<b>RRP</b>		
Change to three phase		



# TTV 2400

REF. 720003

# TTV 4000

REF. 720002



## EQUIPMENT

- Adjustable speed regulator
- Independent power element regulator
- Removable bottom tray

### FEATURES

Power	2.800 W
Weight	20 Kg.
Voltage	230 V - 50/60 Hz
Connection	SINGLE PHASE
External dimension	(W)480 x (D)510 x (H)410 mm.
Cooking chamber dimension	(W)260 x (D)460 x (H)70 mm.
<b>RRP</b>	

### FEATURES

Power	4.000 W
Weight	22 Kg.
Voltage	400 / 230 V - 50/60 Hz
Connection	Single phase
External dimension	(W)570 x (D)620 x (H)400 mm.
Cooking chamber dimension	(W)360 x (D)570 x (H)70 mm.
<b>RRP</b>	
Change to three phase	

# TTH 3002



REF. 720001



## EQUIPMENT

- Adjustable speed regulator
- Independent power element regulator
- Removable bottom tray

## FEATURES

Power		3.000 W
Weight		20 Kg.
Voltage		230 V - 50/60 Hz
Connection		SINGLE PHASE
External dimension		(W)750 x (D)420 x (H)250 mm.
Cooking chamber dimension		(W)200 x (D)500 x (H)70 mm.
<b>RRP</b>		





# PIZZA OVENS



# HP 133

REF. 710100



1 x 350 mm.

# HP 233

REF. 710101





2 x 350 mm.



## EQUIPMENT

- Cooking surface high-quality refractory material
- Cycle end alarm
- Timer 0-60 min. + continuous mode

## FEATURES

Power		2.000 W
Max temperature		320° C
Weight		19 Kg.
Voltage		230 V - 50/60 Hz
Connection		SINGLE PHASE
Cooking chamber dimension		(W)405 x (D)360 x (H)80 mm.
External dimension		(W)535 x (D)535 x (H)261 mm.
<b>RRP</b>		

## FEATURES

Power		3.000 W
Max temperature		320° C
Weight		28 Kg.
Voltage		230 V - 50/60 Hz
Connection		SINGLE PHASE
Cooking chamber dimension		2 x (W)405 x (D)360 x (H)80 mm.
External dimension		(W)535 x (D)535 x (H)390 mm.
<b>RRP</b>		



# HP 433

REF. 710120



4 x 330 mm.

# HP 833

REF. 710112





8 x 330 mm.



## EQUIPMENT

- Cooking surface high-quality refractory material
- LED chamber light
- Independent base/ top temperatura control
- Termometer

## FEATURES

Power		5.600 W
Max temperature		400° C
Weight		90 Kg.
Voltage		400 / 230 V - 50/60 Hz
Connection		Three phase 3F + N + T
Cooking chamber dimension		(W)700 x (D)700 x (H)169 mm.
External dimension		(W)1000 x (D)945 x (H)385 mm.
<b>RRP</b>		
Change to single phase		

## FEATURES

Power		11.200 W
Max temperature		400° C
Weight		140 Kg.
Voltage		400 V - 50/60 Hz
Connection		Three phase 3F + N + T
Cooking chamber dimension		2 x (W)700 x (D)700 x (H)169 mm.
External dimension		(W)1000 x (D)945 x (H)660 mm.
<b>RRP</b>		

# HP 633

REF. 710134



6 x 330 mm.

# HP 1233

REF. 710109





12 x 330 mm.



## EQUIPMENT

- Cooking surface high-quality refractory material
- LED chamber light
- Independent base/ top temperatura control
- Termometer

### FEATURES

Power	8.800 W
Max temperature 	400° C
Weight 	125 Kg.
Voltage 	400 V - 50/60 Hz
Connection	Three phase 3F + N + T
Cooking chamber dimension	(W)1054 x (D)700 x (H)169 mm.
External dimension	(W)1355 x (D)945 x (H)385 mm.
<b>RRP</b>	

### FEATURES

Power	17.600 W
Max temperature 	400° C
Weight 	250 Kg.
Voltage 	400 V - 50/60 Hz
Connection	Three phase 3F + N + T
Cooking chamber dimension	2 x (W)1054 x (D)700 x (H)169 mm.
External dimension	(W)1355 x (D)945 x (H)660 mm.
<b>RRP</b>	



**REGENERATOR**



# RG 311

REF. 740002



3 x GN 1/1

# RG 311 A

REF. 740005



3 x GN 1/1

## EQUIPMENT

- Cycle end alarm
- Reversing gear
- Door safety switch
- Change opening door
- Safety thermostat

## FEATURES

Power		3.900 W
Max temperature		170° C
Weight		39 Kg.
Voltage		230 V - 50/60 Hz
Connection		SINGLE PHASE
Cooking chamber dimension		(W)594 x (D)386 x (H)255 mm.
External dimension		(W)735 x (D)710 x (H)450 mm.
Distance between trays		65 mm.
Humidity		0 % - 100 %
99 cooking programs		With 3 phase each
Water connection		✓
Pre heating		✓
<b>RRP</b>		

## FEATURES

Power		3.900 W
Max temperature		140° C / 160° C
Weight		39 Kg.
Voltage		230 V - 50/60 Hz
Connection		SINGLE PHASE
Cooking chamber dimension		(W)594 x (D)386 x (H)255 mm.
External dimension		(W)735 x (D)710 x (H)450 mm.
Distance between trays		65 mm.
<b>RRP</b>		



# RG 611

REF. 740001



6 x GN 1/1

# RG 611 A

REF. 740004



6 x GN 1/1

## EQUIPMENT

- Cycle end alarm
- Door safety switch
- Safety thermostat
- Reversing gear
- Change opening door

### FEATURES

Power	5.650 W
Max temperature	170° C
Weight	52 Kg.
Voltage	400 / 230 V - 50/60 Hz
Connection	Single phase / Three phase
Cooking chamber dimension	(W)594 x (D)386 x (H)451 mm.
External dimension	(W)735 x (D)710 x (H)720 mm.
Distance between trays	65 mm.
Humidity	0 % - 100 %
99 cooking programs	With 3 phase each
Water connection	✓
Pre heating	✓
<b>RRP</b>	

### FEATURES

Power	5.650 W
Max temperature	140° C / 160° C
Weight	52 Kg.
Voltage	400 / 230 V - 50/60 Hz
Connection	Single phase / Three phase
Cooking chamber dimension	(W)594 x (D)386 x (H)451 mm.
External dimension	(W)735 x (D)710 x (H)720 mm.
Distance between trays	65 mm.
<b>RRP</b>	

# RG 1011

REF. 740003



10 x GN 1/1

# RG 1011 A

REF. 740006



10 x GN 1/1

## EQUIPMENT

- Cycle end alarm
- Reversing gear
- Door safety switch
- Change opening door
- Safety thermostat

## FEATURES

Power		10.300 W
Max temperature		170° C
Weight		85 Kg.
Voltage		400 / 230 V - 50/60 Hz
Connection		Single phase / Three phase
Cooking chamber dimension		(W)594 x (D)386 x (H)710 mm.
External dimension		(W)735 x (D)710 x (H)985 mm.
Distance between trays		65 mm.
Humidity		0 % - 100 %
99 cooking programs		With 3 phase each
Water connection		✓
Pre heating		✓
<b>RRP</b>		

## FEATURES

Power		10.300 W
Max temperature		140° C / 160° C
Weight		85 Kg.
Voltage		400 / 230 V - 50/60 Hz
Connection		Single phase / Three phase
Cooking chamber dimension		(W)594 x (D)386 x (H)710 mm.
External dimension		(W)735 x (D)710 x (H)985 mm.
Distance between trays		65 mm.
<b>RRP</b>		

**GRILL**





# GR 1

REF. 750001



## FEATURES

Power	2.000 W
Max temperature	250° C
Weight	21 Kg.
Voltage	230 V - 50/60 Hz
Connection	SINGLE PHASE
External dimension	(W)330 x (D)430 x (H)260 mm.
Cast iron cooking surface	255 x 245 mm.
<b>RRP GR-1</b>	
RRP GRL-1 ref. 750003	

# GR 2

REF. 750002



## FEATURES

Power	4.000 W
Max temperature	250° C
Weight	40 Kg.
Voltage	230 V - 50/60 Hz
Connection	SINGLE PHASE
External dimension	(W)650 x (D)430 x (H)260 mm.
Cast iron cooking surface	550 x 245 mm.
<b>RRP GR-2</b>	
RRP GRL-2 ref. 750004	

# GR 3

REF. 750007



## FEATURES

Power	3.300 W
Max temperature	250° C
Weight	30 Kg.
Voltage	230 V - 50/60 Hz
Connection	SINGLE PHASE
External dimension	(W)440 x (D)430 x (H)260 mm.
Cast iron cooking surface	360 x 245 mm.
<b>RRP GR-3</b>	
RRP GRL-3 ref. 750008	

## EQUIPMENT

- Cast iron cooking surface
- Front grease collector
- Grooved base and top surface
- Adjustable height up the needs
- Hinged cover brake
- Smooth base cooking surface (GRL-1 / GRL-2 / GRL-3)



**ST-C 200**  
Ref. 710367



**ST-C 400**  
Ref. 710368



**ST-C 650**  
Ref. 710369



COMPATIBLE MODELS	ST-C 1011 / ST-C 611 / ST-C 411	ST-C 1011 / ST-C 611 / ST-C 411	ST-C 611 / ST-C 411
DIMENSIONS	(W)460x(D)670 x(H)200 mm.	(W)460x(D)670 x(H)400 mm.	(W)460x(D)670 x(H)650 mm.
N° of GUIDES	-	-	7
<b>RRP</b>			

**ST-C 850**  
Ref. 710370



**ST-C 650 B**  
Ref. 710371



**ST-C 850 B**  
Ref. 710372



COMPATIBLE MODELS	ST-C 1011	ST-C 423	ST-C 423
DIMENSIONS	(W)460x(D)670 x(H)850 mm.	(W)460x(D)495 x(H)650 mm.	(W)460x(D)495 x(H)850 mm.
N° of GUIDES	10	7	10
<b>RRP</b>			

**STC 200 W**  
Ref. 710424



**STC 400 W**  
Ref. 710421



**STC 650 W**  
Ref. 710422

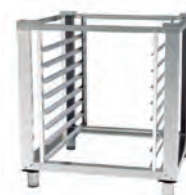

COMPATIBLE MODELS	ST-C 611 W / ST-C 411 W	ST-C 611 W / ST-C 411 W	ST-C 611 W / ST-C 411 W
DIMENSIONS	(W)500 x (D)490 x (H)200 mm.	(W)500 x (D)490 x (H)400 mm.	(W)500 x (D)490 x (H)650 mm.
N° of GUIDES	-	4	8
<b>RRP</b>			

STAND WHEEL CARRIER Ref. 710286 **RRP**



	<b>ST 300</b> Ref. 710299	<b>ST 650</b> Ref. 710300	<b>ST 850</b> Ref. 710305
COMPATIBLE MODELS	ST 604 / ST 604 V7 / ST 606 / ST 606 V7 / ST 610 / ST 610 V7		
DIMENSIONS	(W)770 x (D)720 x (H)300 mm.	(W)770 x (D)720 x (H)650 mm.	(W)770 x (D)720 x (H)850 mm.
N° of GUIDES	-	6	8
<b>RRP</b>			

	<b>ST 300 GN 2/1</b> Ref. 710431	<b>ST 650 GN 2/1</b> Ref. 710432	<b>ST 850 GN 2/1</b> Ref. 710433
COMPATIBLE MODELS	ST 721 / ST 721V7 / ST 1221 / ST 1221 V7		
DIMENSIONS	(W)770 x (D)980 x (H)300 mm.	(W)770 x (D)980 x (H)650 mm.	(W)770 x (D)980 x (H)850 mm.
N° of GUIDES	-	6	8
<b>RRP</b>			

	<b>RXB 300</b> Ref. 710308	<b>RXB 650</b> Ref. 710306	<b>RXB 850</b> Ref. 710302
COMPATIBLE MODELS	RXB 606 / RXB 610 / RXB 606V7 / RXB 610V7		
DIMENSIONS	(W) 715 x (D) 615 x (H) 300 mm.	(W) 715 x (D) 615 x (H) 650 mm.	(W) 715 x (D) 615 x (H) 850 mm.
N° of GUIDES	-	6	8
<b>RRP</b>			

STAND WHEEL CARRIER	Ref. 710286	<b>RRP</b>
---------------------	-------------	------------



	<b>F 450</b> <i>Ref. 710307</i>	<b>F 850</b> <i>Ref. 710301</i>
COMPATIBLE MODELS	F 106 / F 110 / F106V7 / F110V7	F 106 / F 110 / F106V7 / F110V7
DIMENSIONS	(W) 625 x (D) 550 x (H) 450 mm.	(W) 625 x (D) 550 x (H) 850 mm
N° of GUIDES	4	10
<b>RRP</b>		

**SERIES ST 5 GN 1/1**  
*Ref. 180H11*  
**RRP**

**SERIES ST 7 GN 1/1**  
*Ref. 180H12*  
**RRP**

**SERIES ST 12 GN 1/1**  
*Ref. 180H13*  
**RRP**



	<b>RX 43/34</b> <i>Ref. 710077</i>	<b>RX 48/34</b> <i>Ref. 710076</i>	<b>RX 60/40</b> <i>Ref. 710075</i>
COMPATIBLE MODELS	Rx 304 / 384_ME 384	Rx 424 / 484 / 584_ME 424	Rx603/604/604 PLUS/RG311/611/1011
DIMENSIONS	(W) 590 x (D) 580 x (H) 850 mm.	(W) 625 x (D) 640 x (H) 850 mm.	(W) 750 x (D) 700 x (H) 850 mm.
N° of GUIDES	8	8	8
<b>RRP</b>			



	<b>M 60/40</b> <i>Ref. 710123</i>	<b>HP 433</b> <i>Ref. 710135</i>	<b>HP 633</b> <i>Ref. 710136</i>
COMPATIBLE MODELS	M 603 / 604 PLUS / ME 60 3/ 604 PLUS	HP 433 / HP 833	HP 633 / HP 1233
DIMENSIONS	(W) 810 x (D) 700 x (H) 850 mm.	(W) 1000 x (D) 900 x (H) 1100 mm.	(W) 1355 x (D) 900 x (H) 1100 mm.
N° of GUIDES	8	-	-
<b>RRP</b>			

STAND WHEEL CARRIER *Ref. 710286* **RRP**

## EQUIPMENT

- MADE STAINLESS STEEL
- 4 ROTATING WHEELS 2 OF THEM WITH BREAKS
- SLIDING INHIBITORS
- DISTANCE BETWEEN GUIDES 80 mm.
- DETACHABLE FOR TRANSPORTATION

### TROLLEY



### TROLLEY SERIES ST



### PLATE TROLLEY ST



	REF.	COMPATIBLE MODELS	DIMENSIONS	RRP
<b>TROLLEY 10B 60/40</b>	710097	RX 603/604/604 PLUS, MP 603/604, ME 603/604 PLUS, RXB 606/610	(W) 515 x (D) 620 x (H) 1.015 mm.	
<b>TROLLEY 10B 48/34</b>	710099	RX 424/484, ME 424	(W) 455 x (D) 500 x (H) 1.015 mm.	
<b>TROLLEY 20B 60/40</b>	710095	RX 603/604/604 PLUS, MP 603/604, ME 603/604 PLUS, RXB 606/610	(W) 515 x (D) 620 x (H) 1.860 mm.	
<b>TROLLEY 20B 48/34</b>	710098	RX 424/484, ME 424	(W) 455 x (D) 500 x (H) 1.860 mm.	
<b>TROLLEY 20 GN 1/1</b>	710403	All models GN1/1	(W) 440 x (D) 540 x (H) 1.700 mm.	
<b>TROLLEY 20 GN 2/1</b>	710408	All models GN2/1	(W) 640 x (D) 660 x (H) 1.700 mm.	
<b>TROLLEY ST16 60/40</b>	710346	ST 616/T/GAS	(W) 760 x (D) 595 x (H) 1.730 mm.	
<b>TROLLEY ST20 GN 1/1</b>	710347	ST 211/T/GAS	(W) 760 x (D) 595 x (H) 1.765 mm.	
<b>TROLLEY ST20 GN 2/1</b>	710348	ST 221/T/GAS	(W) 760 x (D) 765 x (H) 1.765 mm.	
<b>TROLLEY PLATE GN 1/1</b>	710429	ST 211/T/GAS (64 Plates)	(W) 760 x (D) 595 x (H) 1.765 mm.	
<b>TROLLEY PLATE GN 2/1</b>	710430	ST 221/T/GAS (100 Plates)	(W) 760 x (D) 765 x (H) 1.765 mm.	

PLATE TROLLEY COVER Ref. 710311 RRP



## SERIES ST COMPACT

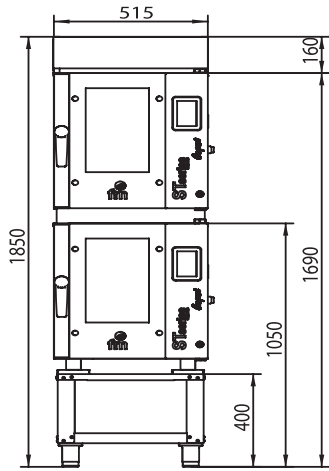

HOOD ST COMPACT  
ST-C611 V5  
ST-C611 V5  
KIT SUPERPOSITION ST-C400

## SERIES ST COMPACT

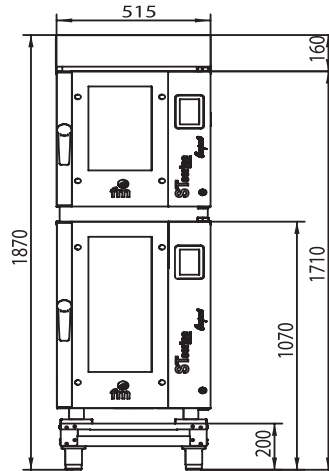

HOOD ST COMPACT  
ST-C611 V5  
ST-C1011 V5  
KIT SUPERPOSITION ST-C200

## SERIES ST COMPACT

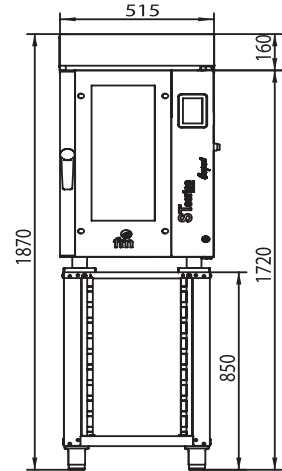

HOOD ST COMPACT  
ST-C1011 V5  
STAND ST-C850

## SERIES ST COMPACT

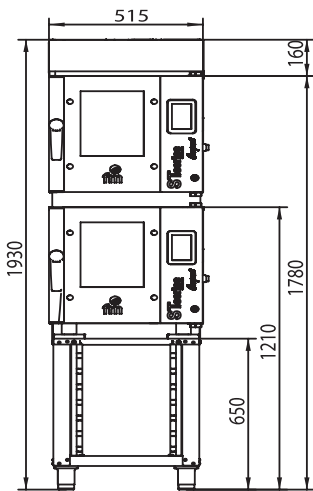

HOOD ST COMPACT  
ST-C411 V5  
ST-C411 V5  
KIT SUPERPOSITION ST-C650

## SERIES ST COMPACT

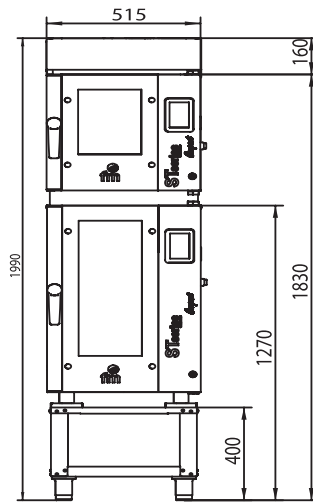

HOOD ST COMPACT  
ST-C411 V5  
ST-C1011 V5  
KIT SUPERPOSITION ST-C400

## SERIES ST COMPACT

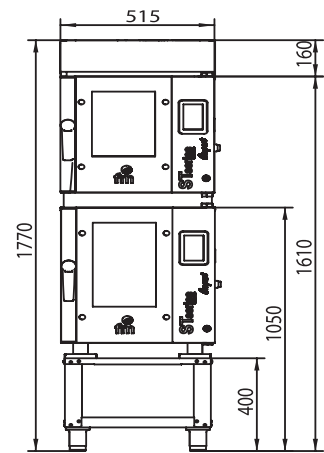

HOOD ST COMPACT  
ST-C411 V5  
ST-C611 V5  
KIT SUPERPOSITION ST-C400

**SERIES ST**

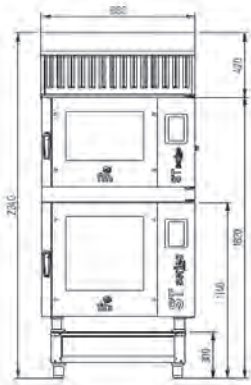

HOOD ST  
ST 604  
ST 606  
STAND ST 300  
KIT SUPERPOSITION SERIES ST

**SERIES ST**

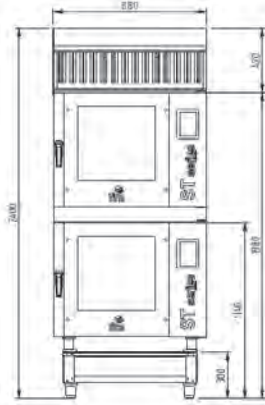

HOOD ST  
ST 606  
ST 606  
STAND ST 300  
KIT SUPERPOSITION SERIES ST

**SERIES ST**

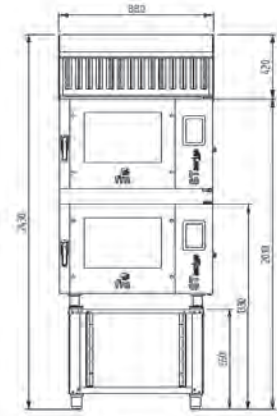

HOOD ST  
ST 604  
ST 604  
STAND ST 300  
KIT SUPERPOSITION SERIES ST

**SERIES F**

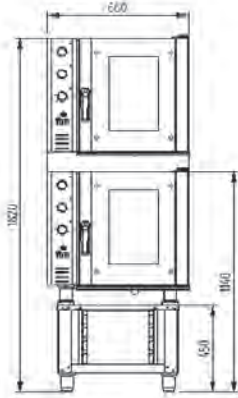

F106  
F106  
STAND F 450  
KIT SUPERPOSITION SERIES F

**SERIES RXB**

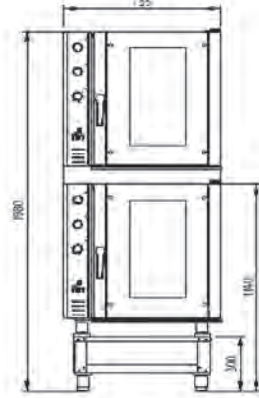

RXB 606  
RXB 606  
STAND RXB300 300  
KIT SUPERPOSITION SERIES RXB

**SERIES RXB**

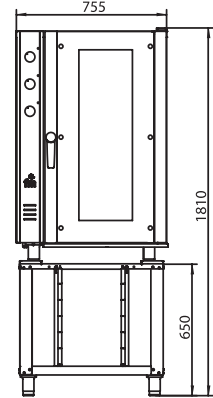

RXB 616  
STAND RXB 650

**SERIES RX**



RXL 424  
RX 424  
STAND RX 48\_34  
KIT SUPERPOSITION RX 48\_34

**SERIES RX**

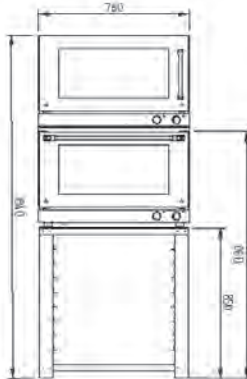

RXL 604 PLUS  
RX 604 PLUS  
STAND RX 60\_40  
KIT SUPERPOSITION SERIES RX 60\_40

**SERIES M**

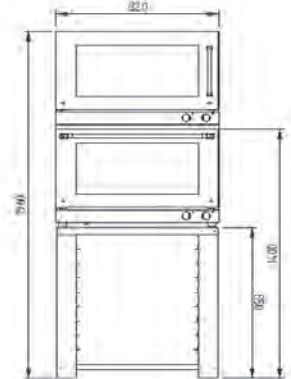

M 604 PLUS L  
M 604 PLUS  
STAND M 60\_40  
KIT SUPERPOSITION SERIES M 60\_40

**BAKERY / PASTRY**

ALUMINIUM FLAT TRAY

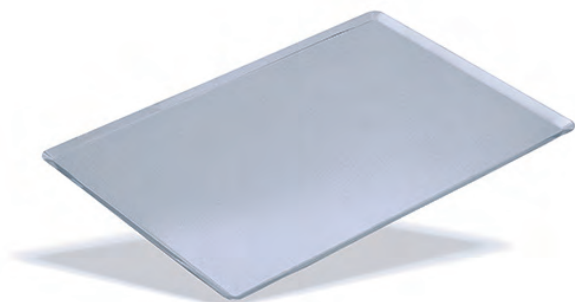

REF.	DIMENSIONS	RRP
810H10	430x340	
810H06	480x340	
810H04	600x400	

PERFORATED ALUMINIUM TRAY

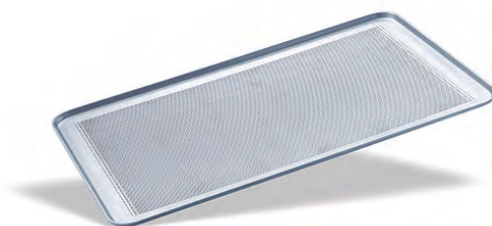

REF.	DIMENSIONS	RRP
810H09	320x240	
810H01	430x340	
810H02	480x340	
810H08	480x440	
810H03	600x400	

INOX. FLAT TRAY

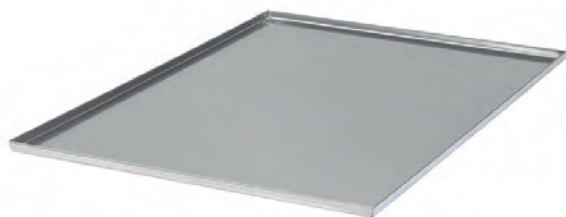

REF.	DIMENSIONS	RRP
860H12	340x240	
860H07	430x340	
860H08	480x340	
860H10	480x440	
860H09	600x400	

FRENCH BAGUETTE TRAY



REF.	DIMENSIONS	RRP
810H05	600x400	

WIRE RACK

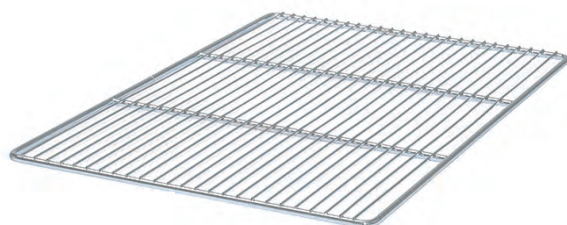

REF.	DIMENSIONS	RRP
820H03	430x340	
820H01	480x340	
820H04	480x440	
820H02	600x400	

INOX. WIRE RACK



REF.	DIMENSIONS	RRP
840H25	GN 2/1	
840H26	GN 1/1	
840H41	600x400	

## GASTRONOMY

STAINLESS STEEL CONTAINER GN 2/1



REF.	DEPTH	RRP
840H04	H20	
840H05	H40	
840H06	H65	

STAINLESS STEEL CONTAINER GN 1/1



REF.	DEPTH	RRP
840H07	H20	
840H08	H40	
840H09	H55	

STAINLESS STEEL CONTAINER GN 2/3



REF.	DEPTH	RRP
840H10	H20	
840H11	H40	
840H12	H65	

PERFORATED STAINLESS STEEL CONTAINER GN 2/1



REF.	DEPTH	RRP
840H13	H20	
840H14	H40	
840H15	H65	

PERFORATED STAINLESS STEEL CONTAINER GN 1/1



REF.	DEPTH	RRP
840H16	H20	
840H17	H40	
840H18	H55	

PERFORATED STAINLESS STEEL CONTAINER GN 2/3



REF.	DEPTH	RRP
840H19	H20	
840H20	H40	
840H21	H65	



**BAKERY / PASTRY**

NONSTICK ALUMINIUM FLAT TRAY

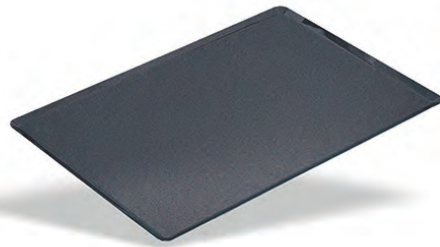

REF.	DIMENSIONS	RRP
810H11	600x400	
840H14	GN 1/1	

NONSTICK ALUMINIUM PERFORATED TRAY



REF.	DIMENSIONS	RRP
810H12	600x400	
840H15	GN 1/1	

EGG TRAY GN



REF.	DIMENSIONS	RRP
840H28	GN 1/1	

NONSTICK ALUMINIUM TRAY GN 1/1 H 65 mm.

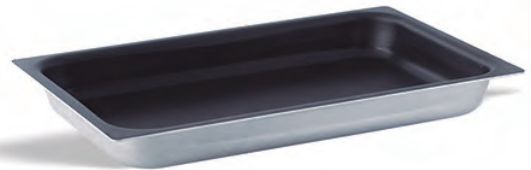

REF.	DIMENSIONS	RRP
840H29	GN 1/1	

NONSTICK GRILL FLAT TRAY GN 1/1



REF.	DIMENSIONS	RRP
840H03	GN 1/1	

DOUBLE NONSTICK TRAY GN 1/1



REF.	DIMENSIONS	RRP
840H38	GN 1/1	

## GASTRONOMY

GRANITE CONTAINER GN 1/1 PROF. 40 MM

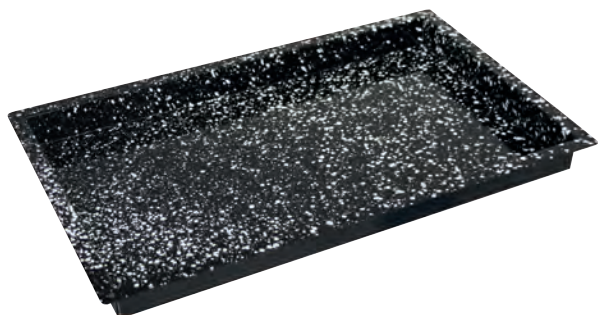

REF.	DIMENSIONS	RRP
840H36	GN 1/1	

NONSTICK GRILL GN 1/1



REF.	DIMENSIONS	RRP
840H37	GN 1/1	

BAKING AND ROASTING PAN



REF.	DIMENSIONS	RRP
840H32	20 cm.	

CHICKEN ROASTING TRAY

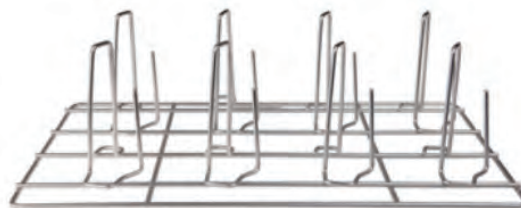

REF.	DIMENSIONS	RRP
840H39	GN 1/1	

RIBS TRAY

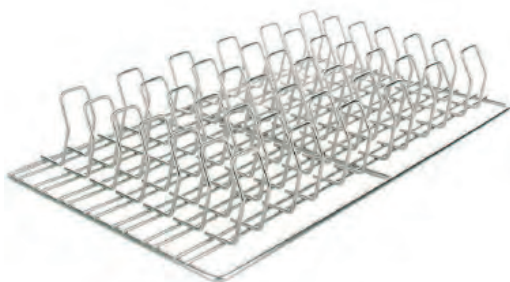

REF.	DIMENSIONS	RRP
840H40	GN 1/1	

FRYING TRAY



REF.	DIMENSIONS	RRP
840H34	GN 1/1	

**PIZZA**

**ALUMINIUM PIZZA PAN**



REF.	DIMENSIONS	RRP
811H01	250 mm.	
811H02	300 mm.	
811H03	350 mm.	

**PIZZA PAN GRID**



REF.	DIMENSIONS	RRP
811H04	250 mm.	
811H05	300 mm.	
811H06	350 mm.	

**PERFORATED BOTTOM TRAY GN**



REF.	DIMENSIONS	RRP
840H22	GN 2/1	
840H23	GN1/1	
840H24	GN 2/3	

**STEAM CONDENSER**



REF.	MODEL	RRP
710191	Steam condenser RX	
710124	Steam condenser RX_H2O	
710265	Steam condenser RX_DUO	
710164	Steam condenser RXB	
710338	Steam condenser SERIES ST	
710339	Steam condenser RXB y F V7	

**KIT FOR SUPERPOSITION**

REF.	MODEL	RRP
710349	KIT SUPERPOSITION RX 43/34	
710287	KIT SUPERPOSITION RX 48/34	
710264	KIT SUPERPOSITION RX 60/40	
710304	KIT SUPERPOSITION M 60/40	
710341	KIT SUPERPOSITION RXB	
710342	KIT SUPERPOSITION F	
710340	KIT SUPERPOSITION ST	
710377	KIT SUPERPOSITION ST Compact	

**PRESSURE REGULATOR 3/4**



REF.	RANGE	RRP
510H52	1 - 6 Bar	

## HOOD COMPACT



## HOOD ST



## HOOD F / RXB



## EQUIPMENT

- MADE OF STAINLESS STEELE
- OPTIONAL MOTOR HOOD Ø 80 mm
- OPTIONAL STEAM CONDENSER
- CONNETION CHIMENEY Ø 200 mm

MODEL	REF.	COMPATIBLE MODELS	DIMENSIONS	RRP
<b>ST COMPACT</b>	710373	STC 411 / 411 ECO / 611 / 1011	(W) 515 x (D) 950 x (H) 160 mm.	
<b>ST</b>	710298	ALL COMPATIBLE MODELS SERIES ST (Except gas models)	(W) 880 x (D) 1.215 x (H) 425 mm.	
<b>ST TROLLEY</b>	710374	ALL COMPATIBLE MODELS SERIES ST (Except gas models)	(W) 880 x (D) 1.215 x (H) 425 mm.	
<b>F</b>	710138	F 106 / F 110	(W) 665 x (D) 900 x (H) 200 mm.	
<b>F V7</b>	710138	F 106 V7 / F 110 V7	(W) 725 x (D) 900 x (H) 200 mm.	
<b>RXB</b>	710137	RXB 606 / RXB 610	(W) 755 x (D) 965 x (H) 200 mm.	
<b>RXB V7</b>	710261	RXB 606 V7 / RXB 610 V7	(W) 815 x (D) 965 x (H) 200 mm.	
<b>HP 433</b>	710139	HP 433 / HP 833	(W) 1.000 x (D) 1.180 x (H) 200 mm.	
<b>HP 633</b>	710140	HP 633 / HP 1233	(W) 1.355 x (D) 1.180 x (H) 200 mm.	

MODEL	REF.	COMPATIBLE MODELS	RRP
<b>KIT Steam condenser HOOD SERIES ST</b>	710387	All models ST	
<b>KIT Steam condenser HOOD SERIES F / RXB</b>	710389	All models F y RXB	
<b>KIT Steam condenser HOOD SERIES HP</b>	710391	HP 433 / 633 / 833 / 1233	
<b>KIT Steam motor ST</b>	710388	All models ST	
<b>KIT Steam motor F / RXB</b>	710390	All models F y RXB	
<b>KIT Steam motor HP</b>	710392	HP 433 / 633 / 833 / 1233	



## AUTOMATIC WASHING SYSTEM



REF.	RRP
710141	

## HAND SHOWER



REF.	RRP
710310	

## BAKER MITTS



REF.	RRP
870H01	

## DETERGENT 5L.



REF.	RRP
870H02	

## RINSE AID 5L.



REF.	RRP
870H03	

## FILTER

### WATER SOFTENER



REF.	RRP
710352	

### HEAD CONNETION



REF.	RRP
710350	

REF. 710090	DIGIMETER	RRP
-------------	-----------	-----

## VACUUM CORE PROBE



REF.	RRP
710376	

## REMOVABLE CORE PROBE



REF.	RRP
710375	

## CORE PROBE PLACEMENT



REF.	RRP
710343	

FIRST INSTALLATION KIT	Ref. 710434	RRP
------------------------	-------------	-----







[www.fmindustrial.es](http://www.fmindustrial.es)







14900 LUCENA (Córdoba)  
Apdo. de correos 98  
SPAIN

tfno. (0034) 957 501 101 / fax. (0034) 957 590 128  
e-mail: [fmindustrial@fmindustrial.es](mailto:fmindustrial@fmindustrial.es)

[www.fmindustrial.es](http://www.fmindustrial.es)